

Solid Door Freezers

Digital Temperature Control System



M3F24-1



M3F47-2



M3F72-3

FEATURES / BENEFITS

- **DIGITAL TEMPERATURE CONTROL SYSTEM**
Provides precise and constant temperature. This level of precision allows food products to remain fresh over an extended period of time.
- **HIGH-TECH MONITOR**
The monitor digitally displays the present temperature. You can easily change the temperature by adjusting the thermostat.
- **EFFICIENT REFRIGERATION SYSTEM**
M3's solid door freezers are designed with oversized and balanced (CFC Free R-404A) refrigeration systems. These include efficient evaporators and condensers for faster freezing and greater efficiency.
- **AUTOMATIC EVAPORATOR FAN MOTOR DELAYS**
Through stopping the evaporator fan when the freezer door opens, the circulation of hot, moist air into the freezer is prevented. This increases energy efficiency and lengthens the life of the compressor.
- **STAINLESS STEEL CABINET CONSTRUCTION**
The Turbo Air M3 freezer model boasts a stainless steel interior and exterior (except the coated AL inside wall and the back). It guarantees the utmost in cleanliness and long product life. Unlike other companies' products, the sharp corners and edges have been rounded to reduce the risk of injury. The M3 can add a touch of style to the most refined setting.
- **ADJUSTABLE, HEAVY DUTY, PE(POLYETHYLENE) COATED WIRE SHELVES**
- **HIGH-DENSITY POLYURETHANE INSULATION**
The entire cabinet structure and solid doors are formed-in-place using high density, CFC free polyurethane insulation.
- **ERGONOMICALLY DESIGNED DOOR**
Customers' fatigue fades away with easy grip handles and doors that open effortlessly. These features along with self-closing doors make this the ultimate choice in customer convenience.
- **MAGNETIC DOOR GASKET**
Magnetic door gaskets are of one piece construction, removable without tools for ease of cleaning and replacement.
- **HOT GAS CONDENSATE SYSTEM**
Through Turbo Air's creative innovation, the condensate system surfaces have been specially treated to resist corrosion. This not only increases efficiency without the risk of refrigerant leakage from corrosion, but also prevents the overflow of condensate water.
- **TOP MOUNT COMPRESSOR UNITS**
The refrigeration systems are designed to ensure that each part is properly sized and balanced to achieve the highest efficiency and performance.
- **FREEZER MAINTAINS -10°F ~ 0°F FOR THE BEST IN FROZEN FOOD PRESERVATION**

Model	Swing Door	CU./FT.	#of Shelves	HP	AMPS	Crated Weight	L D H
M3F24-1	1	24	3	1/2	7.8	307	28 3/4 x 28 1/3 x 78
M3F47-2	2	47	6	3/4	10.5	445	51 3/4 x 28 1/3 x 78
M3F72-3	3	72	9	1 1/4	10.4	673	77 4/5 x 28 1/3 x 78

- Depth does not include 1-3/8" for rear condensate enclosure.
- Height does not include 6" for caster height.
- Requires 115/208-230/60Hz, single phase, 3 pole, 4 wire circuit (models M3F72-3 only). Design and specifications subject to change without prior notice.

Distributed By:
Commercial Refrigeration Service, Inc.
<http://WWW.IceCubes.NET>
623-869-8881 or toll free 866-IceMakers

M3F24-1 / M3F47-2 / M3F72-3 SPECIFICATIONS

ELECTRICAL DATA	M3F24-1	M3F47-2	M3F72-3
Voltage (i) NEMA-5-15P (ii) NEMA-L14-20	(i) 115/60-1	(i) 115/60-1	(ii) 115/208~230
Amperes	7.8 A	10.5 A	10.4 A
Compressor (HP)	1/2	3/4	1 1/4
Feed Wires (with ground)	3	3	4
Cord Length	8.2 ft.	8.2 ft.	9.2 ft.
** M3F72-3 requires dual voltage 115/208~230V			
DIMENSIONAL DATA			
# of Doors	1	2	3
Cubic Feet	24	47	72
# of Racks Accepted	1	2	3
Length Overall (in)	28 3/4	51 3/4	77 4/5
Depth Overall (in)	28 1/3	28 1/3	28 1/3
Height Overall (in)	78	78	78
Interior Dimension (LxDxH)	24 4/5x24 3/5x60 5/7	47 4/5x24 3/5x60 5/7	74x24 3/5x60 5/7
Shelf Size	23 1/2x23 2/3	23 1/2x23 1/9	23 1/2x25 1/3
# of Shelves	3	6	9
** Depth does not include 1-3/8" for rear condensate enclosure			

- INCANDESCENT INTERIOR LIGHTING
- DOOR LOCKS
- SELF-CONTAINED SYSTEM
- 4" SWIVEL CASTERS
- SOLID AND STURDY GRILLE DESIGN
- LEGS AVAILABLE FOR ALL MODELS (OPTION)
- TRAY RACK AVAILABLE (OPTION)
All models accept full size tray racks.
- REMOTE CABINETS AND CONDENSING UNITS AVAILABLE FOR ALL MODELS.

Distributed By:
 Commercial Refrigeration Service, Inc.
<http://WWW.IceCubes.NET>
 623-869-8881 or toll free 866-IceMakers

*Design and specifications subject to change without notice.

- **WARRANTY : 1 Year Labor and Parts Warranty**
Additional 4 Years Warranty on Compressor

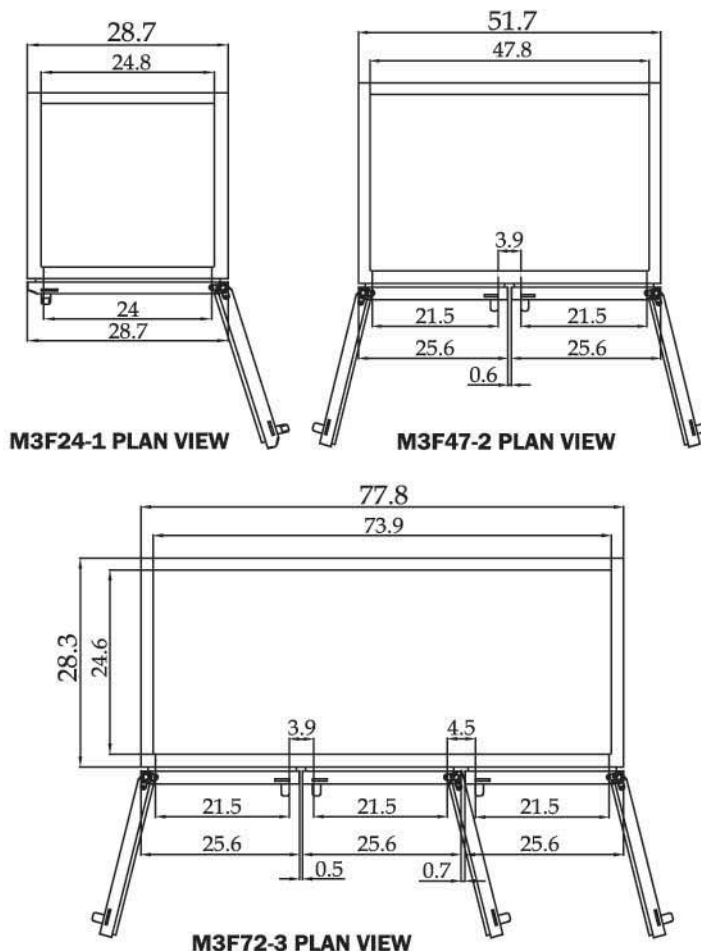

(unit : inch)

