

REFRIGERATOR MANUFACTURER

Turbo air

Undercounter Freezers

M3 Series

Unique Energy Saving Design



MUF-28



MUF-48



MUF-60

Distributed By:
 Commercial Refrigeration Service, Inc.
<http://WWW.IceCubes.NET>
 623-869-8881 or toll free 866-IceMakers

FEATURES / BENEFITS

- **EFFICIENT REFRIGERATION SYSTEM**
 M3's solid door freezers are designed with oversized and balanced (CFC Free R404A) refrigeration systems. These include efficient evaporators and condensers for faster freezing and greater efficiency.
- **STAINLESS STEEL LOUVER**
 Built to withstand food acids and stains, stainless steel louvers ensure even distribution of cold air throughout the interior of the unit.
- **STAINLESS STEEL CABINET CONSTRUCTION**
 The Turbo Air M3 model boasts a stainless steel interior and exterior (except inside wall and the back). It guarantees the utmost in cleanliness and long product life. The M3 can add a touch of style to the most refined setting.
- **HIGH-DENSITY POLYURETHANE INSULATION**
 The entire cabinet structure and solid doors are formed-in-place using high density, CFC free polyurethane insulation.
- **ADJUSTABLE, HEAVY DUTY, PE(POLYETHYLENE) COATED WIRE SHELVES**
- **ERGONOMICALLY DESIGNED DOOR**
 Customers' fatigue fades away with easy grip handles and doors that open effortlessly. These features along with self-closing doors make this the ultimate choice in customer convenience. ABS sheet door liners resist water condensation with thermal efficiency.
- **MAGNETIC DOOR GASKET**
 Magnetic door gaskets are of one piece construction, removable without tools for ease of cleaning and replacement.
- **HOT GAS CONDENSATE SYSTEM**
 Through Turbo Air's creative innovation, the condensate system surfaces have been specially treated to resist corrosion. This not only increases efficiency without the risk of refrigerant leakage from corrosion, but also prevents the overflow of condensate water.
- **FREEZER HOLDS -5°F ~ -10°F FOR THE BEST IN FROZEN FOOD PRESERVATION**

Model	Swing Door	CU./FT.	#of Shelves	HP	AMPS	Crated Weight	L D H
MUF-28	1	7	1	1/3	53	159	27 1/2 x 30 x 30 1/3
MUF-48	2	12	2	1/2	83	234	48 2/9 x 30 x 30 1/3
MUF-60	2	16	2	1/2	90	278	60 1/4 x 30 x 30 1/3

* Height does not include 6" for caster height.

MUF-28 / MUF-48 / MUF-60 SPECIFICATIONS

MODEL	MUF-28	MUF-48	MUF-60
Exterior Dimension(LxDxH)	27 ¹ / ₂ x30x30 ¹ / ₃	48 ² / ₉ x30x30 ¹ / ₃	60 ¹ / ₄ x30x30 ¹ / ₃
Cubic Feet	7	12	16
Compressor (HP)	1/3	1/2	1/2
Shelves	1 ea	2 ea	2 ea
Net Weight	150lbs	221lbs	262lbs
Voltage Ⓢ ¹ NEMA 5-15P	Ⓢ ¹ 115V / 60Hz	Ⓢ ¹ 115V / 60Hz	Ⓢ ¹ 115V / 60Hz
Amp	5.3 A	8.3 A	9.0 A
Lamp	25W	25W	25W
Cord Length	9.2 ft.	9.2 ft.	9.2 ft.
Plug-In	NEMA 5-15P	NEMA 5-15P	NEMA 5-15p

- SELF-CONTAINED SYSTEM
- 5" SWIVEL CASTERS
- STAINLESS STEEL BACK SPLASH (OPTION)
- LEGS AVAILABLE FOR ALL MODELS (OPTION)
- REMOTE CABINETS AND CONDENSING UNITS AVAILABLE FOR ALL MODELS.

*Design and specifications subject to change without notice.

- **WARRANTY :** 1 Years Labor and Parts Warranty
 Additional 4 Years Warranty on Compressor

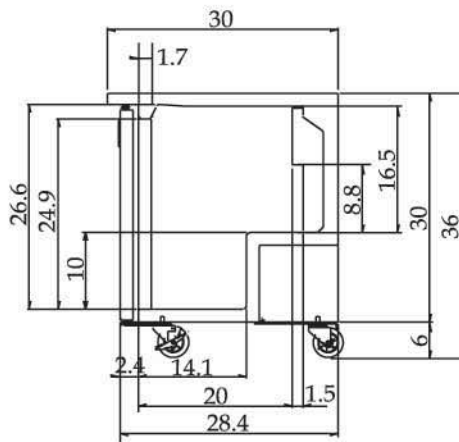

SIDE VIEW

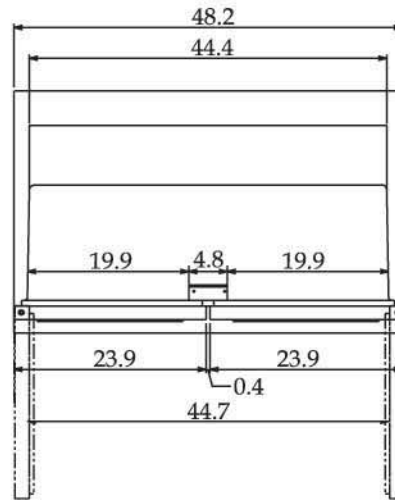

MUF-48 PLAN VIEW

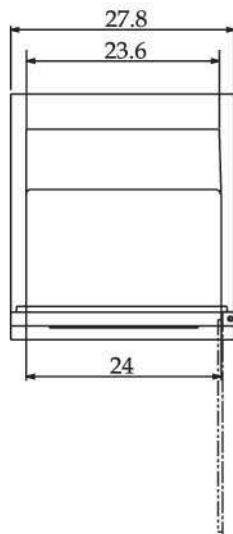

MUF-28 PLAN VIEW

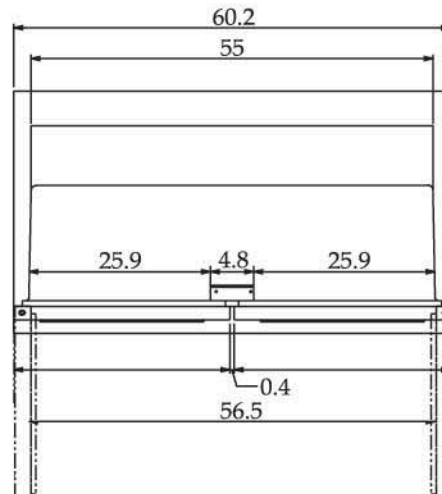

MUF-60 PLAN VIEW

(unit : inch)