

24" UNDERCOUNTER REFRIGERATOR

SMALL FOOTPRINT

BIG SPACE SAVER

- Compact 24" unit saves valuable floor space
- Automatic defrost with forced air circulation
- Heavy-duty construction is built to last
- Front breathing design saves floor space



Model SKR24

SILVER KING[®]
WE'VE GOT REFRIGERATION DOWN COLD™

24" UNDERCOUNTER REFRIGERATOR SPECIFICATIONS

MODEL SKR24	EXTERIOR	Stainless steel. Galvanized back. Stainless steel back optional.
	INTERIOR	Corrosion-resistant material with coved corners throughout for easy cleaning and sanitation.
	INSULATION	Environmentally friendly foamed-in-place polyurethane insulation for maximum strength and durability.
	DOOR	Polyurethane insulation, heavy-duty extruded aluminum frame, stainless steel exterior door panel and extra heavy-duty magnetic "Thermo Rubber" door gaskets combine to make the toughest, longest lasting door in the industry. Door liner is high impact ABS and door is easily field reversible.
	SHELVES	Heavy gauge wire shelves are hand dipped, not sprayed, providing double thick epoxy coating for superior durability and smooth finish. Adjustable in 1/2" increments on stainless steel pilasters.
	CASTERS	Supplied with heavy-duty casters, (two with locks) threaded to Rivnuts, secured to a 12 gauge steel base to ensure years of trouble free operation.
	REFRIGERATION	CFC-free refrigerant. Hermetically sealed, high efficiency, self contained refrigeration system features automatic defrost and forced air circulation. Evaporator coil positioned for uniform air distribution and optimum cooling. Adjustable temperature control and built-in temperature indicator standard. Automatic condensate evaporator means no plumbing or floor drains.
	ELECTRICAL	Standard as 115 volt, 60Hz, single phase operation. 8 foot, 3-wire power cord with NEMA 5-15 plug. Available in 230 volt, 50 Hz, single phase.
	LISTINGS	ETL (U.S. and Canada), NSF International.
	WARRANTY	One year parts and labor warranty on cabinet and refrigeration system. Five year warranty on compressor.
	ACCESSORIES	Mobility Kit, Stainless Steel Back Cover Kit, Glass Door.

MODEL	LENGTH	DEPTH	HEIGHT	STORAGE CAPACITY	SHELVES	SHELF AREA	COMPRESSOR	AMPS	WEIGHT
SKR24	24"	25"	32"	4.4 cu. ft.	2	5.9 sq. ft.	1/5 hp	2.15	165 lbs



Specifications subject to change without notice.

Dimensions in inches and centimeters

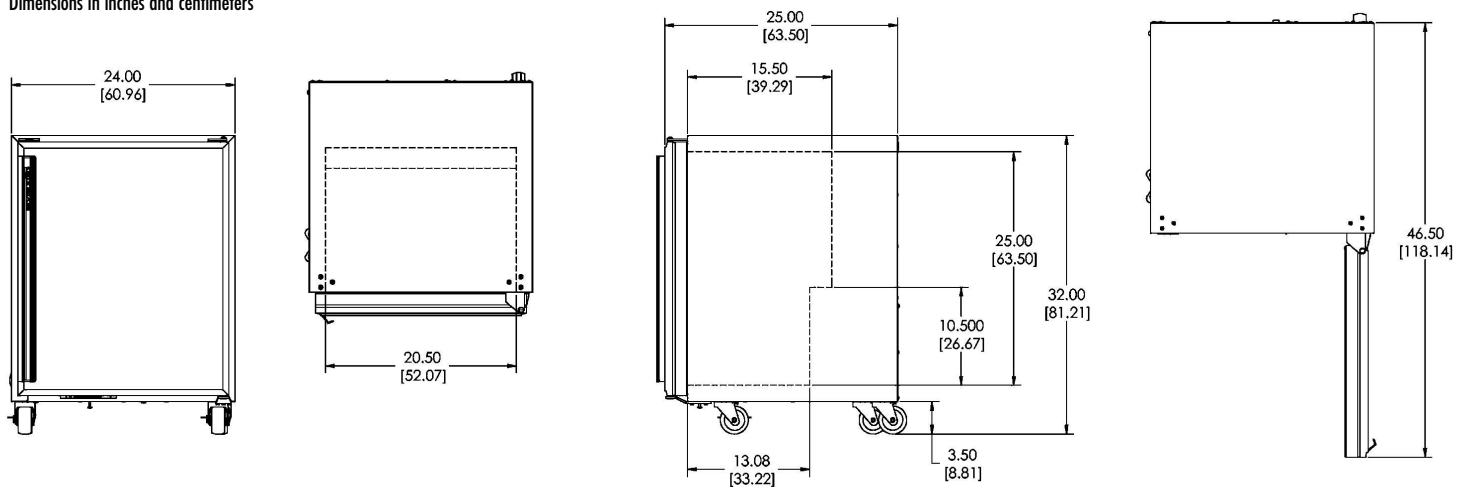

1600 Xenium Lane North
 Minneapolis, MN 55441-3787
 Phone (763) 923-2441
 Fax (763) 553-1209
 www.silverking.com

#FNSKR403
 © Silver King 2003
 Printed in U.S.A.