

# SM50 Series Ice Cube Machine

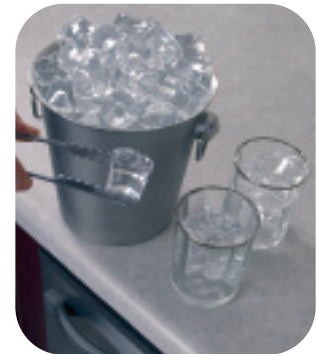

SM50 Series



- Produces 53 lbs. (24 kgs.) of ice in 24 hours with storage capacity of 25 lbs. (11 kgs.)
- Individual cubes with unique octagon shape
- Designed to be installed into standard cabinet dimensions 15.00" (38.00 cm) or stand alone with stainless steel top and sides standard
- Unit ships with hinge on right, easily changed to left during installation
- Easily accessible control panel with the following functionality:
  - Automatic ice making mode
  - Patented cleaning and sanitizing
  - Delay start option
  - Filter replacement warning light
- Water filter system integrated inside machine with depth filtration and scale inhibitor
- Lighted bin (LED light) with large opening for easy access
- Optional drain pump easily integrates inside the machine during installation
- 3-year parts and labor warranty on entire machine

Note: This product is intended exclusively for commercial application. No warranty is extended for personal, family, or household purposes.

**America's #1 Selling Ice Machine**

Ice Cube & Flake Machines • Ice Storage Bins • Ice Dispensers



# Manitowoc SM50 Series

Model	Ice Shape	Ice production 24 hours		Power kWh/100 lbs. @ 90°/70°
		lbs.	kgs.	
SM50A	Standard	53	24	11.89
Water usage/100 lbs./45.4 kgs. of ice				
Potable Water: 48 gallons, 182 liters				

\*A following model number indicates "Air" cooled condensing unit.

## Ice Machine Electric

115/60/1. Factory pre-wired with a 6' (180 cm) power cord and NEMA 5-15P-plug configuration.

**Total Amps:** 4.1 amps.

**Maximum Fuse Size:** 15 amps.

HACR-type circuit breakers can be used in place of fuses.

## Specifications

### BTU Per Hour:

1,145 (average) 2,300 (peak)

### Compressor:

Nominal rating: 1/6 HP

### Operating Limits:

- **Ambient Temperature Range:** 50° to 110°F (10° to 43°C)
- **Water Temperature Range:** 35° to 90°F (2° to 32°C)
- **Water Pressure Ice Maker Water In:** Min. 20 psi (138 kPa) Max. 80 psi (551 kPa)

### Legs:

Levelers standard 0" to 1" (0-2.5 cm) adjustability. Optional legs 4.25"-6.00" (10.80-15.24 cm).

### Insulation:

Insulation foamed-in-place with CFC-FREE foam.



## Air Flow Front View

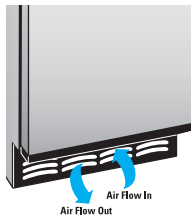

Air in right, air out left, no side vents.

## Water Filter



Auto-bypass for easy change out.

## Cube Size

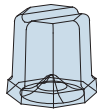

Standard 1-3/8" x 1-3/8" (33 x 34 mm)

## Front Access Control Panel



Machine automatically keeps the bin full. Choose delay start for optimal quietness. Machine automatically restarts.

24-HOUR PRODUCTION † lbs. kgs.			
AIR-COOLED UNIT			
air temp	water temp		
°F	50°	70°	90°
°C	10°	21°	32°
70°	53	53	53
21°	24	24	24
80°	50	49	48
27°	23	22	21
90°	48	44	43
32°	21	20	19

†16 cubes per ice cycle.

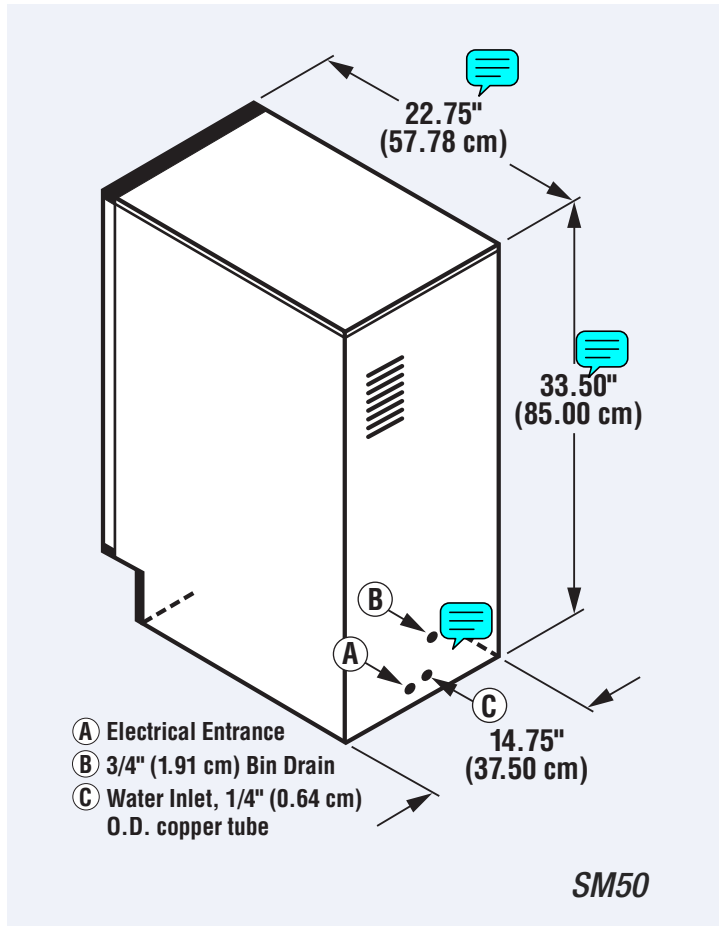

**Installation Note** - There is no minimum clearance required, designed to be integrated into cabinet opening 15.00" (38.00 cm) wide.

© 2008 Manitowoc 11/08 Continuing product improvement may necessitate change of specifications without notice.

3404D



We are committed to protecting the environment and its resources. For up-to-date product data always view an electronic version on our web site.



MANITOWOC ICE  
 2110 South 26th Street, P.O. Box 1720  
 Manitowoc, WI 54221-1720, USA  
 Ph: 920-682-0161 • Fax: 920-683-7566  
 Visit us online at [www.manitowocice.com](http://www.manitowocice.com)

