

QM30 Series Ice Cube Machine



QM30 Series

- Compact size. Produces up to 65 lbs. (30 kgs.) of ice every 24 hours with a storage capacity of 30 lbs. (14 kgs.) Ideal for any small-volume ice need.
- Attractive stainless steel cabinet – euro-design
- Easy access door, slides up & out of the way
- Patented cleaning and sanitizing technology
- Easy access air filter
- Front air intake and exhaust
- CFC-FREE R-134A refrigerant
- Manitowoc proven vertical evaporator
- Computerized control
- 3-year parts-and-labor warranty

America's #1 Selling Ice Machine

Ice Cube & Flake Machines • Ice Storage Bins • Ice Dispensers



Manitowoc QM30 Series

Model	Cube size	Ice production 24 hours		Power kWh/100 lbs.
		lbs.	kgs.	
QM30A	dice	52	24	20.4
Water usage/100 lbs./45.4 kgs. of ice				
Potable Water: 38.4 gallons, 146 liters				

A following model number indicates *Air* cooled condensing unit.



Certified in Accordance with ARI Ice Storage Bins Certification Program, which is based on ARI Standard 820

Ice Machine Electric

115/60/1. (230/50/1 also available.) 115/60/1 ice machines are factory pre-wired with a 6' (180 cm) power cord and NEMA 5-15P-plug configuration.

Total Amps: 5.3 amps.

Maximum fuse size: 15 amps.

HACR-type circuit breakers can be used in place of fuses.

Specifications

BTU Per Hour:

1,600 (average) 2,350 (peak)

Compressor:

Nominal rating: 1/4 HP

Operating Limits:

• Ambient Temperature Range:

50° to 113°F (10° to 45°C)

• Water Temperature Range:

50° to 104°F (10° to 40°C)

• Water Pressure Ice Maker Water In:

Min. 34 psi (240 kPa)

Max. 90 psi (620 kPa)

Legs:

Adjustable from 6.00"-7.25" (15.24-17.78 cm).

Ice Storage:

One piece bin liner (seamless) "rotocast" polyethylene.

Insulation:

Insulation foamed-in-place with CFC-FREE foam.



Air Flow Front View

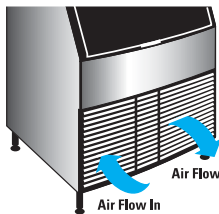

Air in left, air out right, no side vents.

Air Filter



Slides out from left side front without tools, easy to clean, reusable filter protects condenser from lint, grease and dust.

Cube Size



Dice
7/8" x 7/8" x 7/8"
(2.22 x 2.22 x 2.22 cm)

Front Access

Initiate ice, off and clean operations with simple upfront selector switch. No need to remove front panel.



24-HOUR PRODUCTION †		lbs. kgs.	
AIR-COOLED UNIT			
air temp	water temp		
°F	50°	70°	90°
°C	10°	21°	32°
70°	65	60	
21°	30	28	
80°	60	56	50
27°	28	25	23
90°	55	52	47
32°	25	24	21

†Production for Dice cubes.

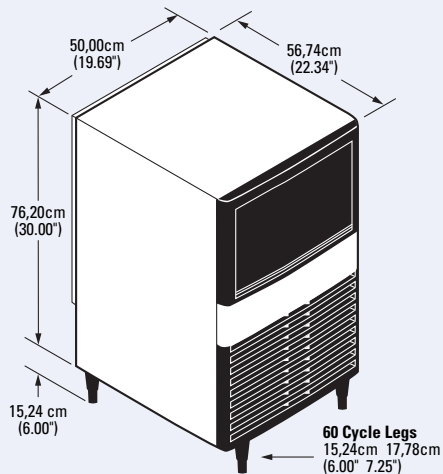

60 Cycle Legs
15.24cm 17.78cm
(6.00" 7.25")

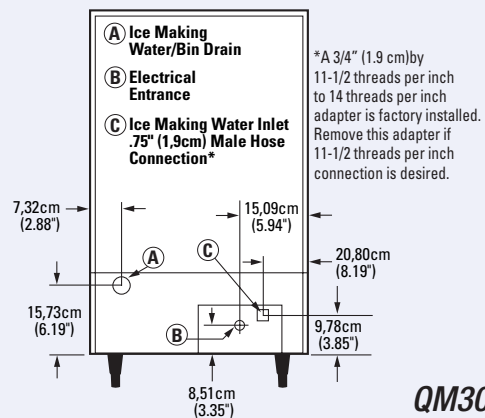

*A 3/4" (1.9 cm) by 11-1/2 threads per inch to 14 threads per inch adapter is factory installed. Remove this adapter if 11-1/2 threads per inch connection is desired.

QM30

Installation Note - There is no minimum clearance required, however recommended clearance for top, sides, and back is 5" (12.7 cm).

©2014 Manitowoc 3019 - 9/04. Continuing product improvement may necessitate change of specifications without notice.



MANITOWOC ICE, INC.
2110 South 26th Street, P.O. Box 1720
Manitowoc, WI 54221-1720, USA
Ph: 920-682-0161 • Fax: 920-683-7589
Visit us online at www.manitowocice.com

