

KM-151BAH

SELF-CONTAINED CUBER WITH BUILT-IN STORAGE BIN

Item # _____

Project: _____

Qty: _____

*AutoCad available on KCL

KM-151BAH

4/08

Item # 13210

CUBER DIMENSIONS

W x D x H

KM-151BAH



23^{3/4} x 28 x 39*

* with 6" legs



KM-151BAH

Air-Cooled
Shown

- Up to 146 lbs. of ice production per 24 hours
- Up to 78 lbs. of built-in storage capacity
- Individual crescent cube
- Durable stainless steel exterior
- CycleSaver® Design 
- EverCheck® alert system 
- Front in, front out airflow
- Stainless steel evaporator
- Slide in door
- Removable air filter
- Power switch accessible without panel removal
- Built-in installation possible
- Complies with California Energy Commission (CEC)
- R-134a Refrigerant

* The KM-151BAH is ENERGY STAR certified.

Distributed By:
Commercial Refrigeration Service, Inc.
WWW.IceCubes.NET
(866) 423-6253
(623) 869-8881



Warranty

Valid in United States, Canada, Puerto Rico, & U.S. Territories. Contact factory for warranty in other countries.

Three Year - Parts & Labor on entire machine.

Five Year - Parts & Labor on: Evaporator.

Five Year - Parts on: Compressor, air-cooled condenser coil.



SELF-CONTAINED CUBER WITH BUILT-IN STORAGE BIN

KM-151BAH

DIMENSIONS

W x D x H

KM-151BAH
23^{3/4} x 28 x 39*
*with 6" legs

• Air-cooled

AIR-COOLED

| Water Temp° F. | 50° | 70° | 90° |
|------------------|-----|-----|-----|
| Air Temp° F. 70° | 146 | 139 | 129 |
| 80° | 140 | 129 | 119 |
| 90° | 139 | 121 | 111 |

UTILITY CONSUMPTION

| Model Number | Ice Production Per Cycle | | KWH per 100 LBS. | Potable Water Gal. per 100 lbs. | Condenser Water Gal. per 100 lbs. |
|--------------|--------------------------|-------|------------------|---------------------------------|-----------------------------------|
| | Lbs. | Cubes | | | |
| KM-151BAH | 2.75 | 130 | 8.4 | 17.8 | N/A |

SPECIFICATIONS

| Model Number | Condenser | Amperage | Min. Circuit Ampacity | Shipping Weight |
|--------------|------------|----------|-----------------------|-----------------|
| KM-151BAH | Air-Cooled | 7.0 | 15A | 150 lbs. |

KM CUBE DIMENSIONS

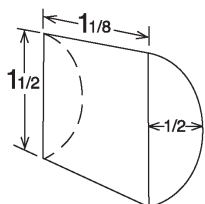

Distributed By:
Commercial Refrigeration Service, Inc.
WWW.IceCubes.NET
(866) 423-6253
(623) 869-8881

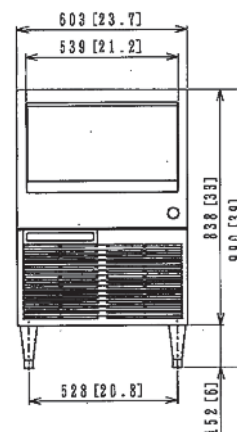

FRONT DIMENSIONS

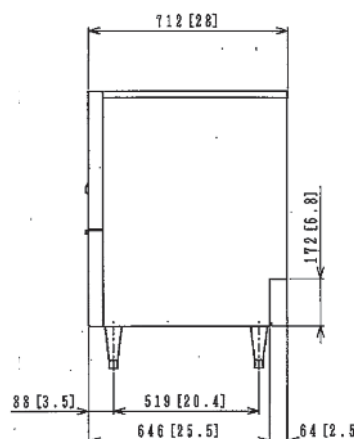

SIDE DIMENSIONS

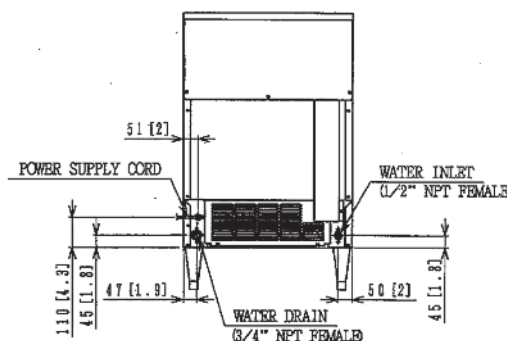

BACK DIMENSIONS

ELECTRICAL & PLUMBING/KM-151BAH

- 115V/60/1
- 15 amp Max Fuse/HACR Breaker Size
- 3/8" OD copper or equivalent independent potable water supply
- 3/4" independent drain connection
- 1/2" FPT Water Inlet



© HOSHIZAKI AMERICA, INC.

OPERATING LIMITS

- Ambient Temp Range 45 - 100°F
- Water Temp Range 45 - 90°F
- Water Pressure 10 - 113psig
- Voltage Range 104 - 127V

