

DCM-270BAH

SANITARY CUBELET ICE MACHINE/DISPENSER

Item # _____

Project: _____

Qty: _____

*AutoCad available on KCL

DCM-270BAH

5/06

Item # 13116

DIMENSIONS

W x D x H

DCM-270BAH

16^{9/16} x 24^{3/16} x 31^{7/8}*
*with 4" legs

SD-270

16^{1/2} x 24 x 35^{3/16}



DCM-270



SD-270
optional
stand

DCM-270BAH

Air-Cooled
Shown



DCM-270BAH

- CleanCycle12® - Every 12 hours, unit performs 15 minute purge to rid itself of impurities
- Durable stainless steel exterior
- Up to 282 lbs. of ice production per 24 hours
- Easy to chew, cubelet ice
- Self contained design reducing opportunities for cross contamination
- Dispenses ice and water
- Removable air filter
- Stainless steel internal auger
- R-404A Refrigerant



SD-270 Stand

- Heavy duty stand for floor model icemaker/dispenser
- Corrosion resistant stainless steel exterior
- Easy cleaning with attractive appearance
- Locking door



Warranty

Valid in United States, Canada, Puerto Rico, & U.S. Territories. Contact factory for warranty in other countries.

Two Year - Parts & Labor on entire machine.

Five Year - Parts on: hermetic compressor, air-cooled fin and tube type condenser.



Hoshizaki

DCM-270BAH SANITARY CUBELET ICE MACHINE/DISPENSER

DIMENSIONS W x D x H

DCM-270BAH
16^{9/16} x 24^{3/16} x 31^{7/8}
*with 4" legs

SD-270
16^{1/2} x 24 x 35^{3/16}

- Air-cooled
- Optional stand with locking door

AIR-COOLED

| Water Temp° F. | 50° | 70° | 90° |
|------------------|-----|------------|-----|
| Air Temp° F. 70° | 282 | 271 | 259 |
| Air Temp° F. 80° | 248 | 238 | 228 |
| Air Temp° F. 90° | 219 | 215 | 201 |

UTILITY CONSUMPTION

| Model Number | KWH per 100 LBS. | | GAL per 100 LBS. | |
|--------------|------------------|-------|------------------|-------|
| | 90/70 | 70/50 | 90/70 | 70/50 |
| DCM-270BAH | 7.6 | 5.5 | 12.0 | 12.0 |

SPECIFICATIONS

| Model Number | Condenser | Amperage | Shipping Weight |
|--------------|------------|----------|-----------------|
| DCM-270BAH | Air-Cooled | 8.5 | 165 lbs. |
| SD-270 | N/A | N/A | 95 lbs. |

Flaked Ice compacted into Cubelets by Extruding Head Cutter and stored in an Insulated Bin with Continuous Agitation during Dispensing and Direct Dispensing Auger

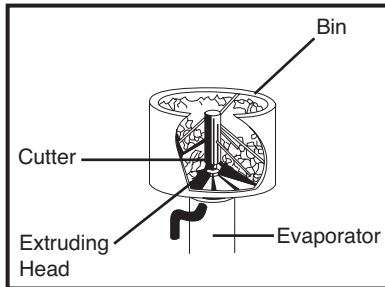

Evaporator

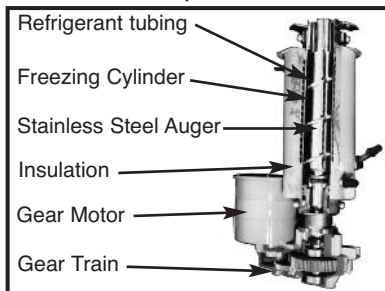

9 lb. Capacity Built-in Bin

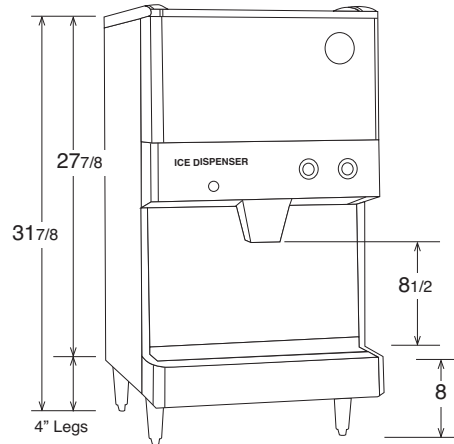

DCM-270

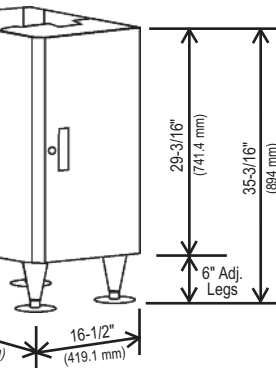
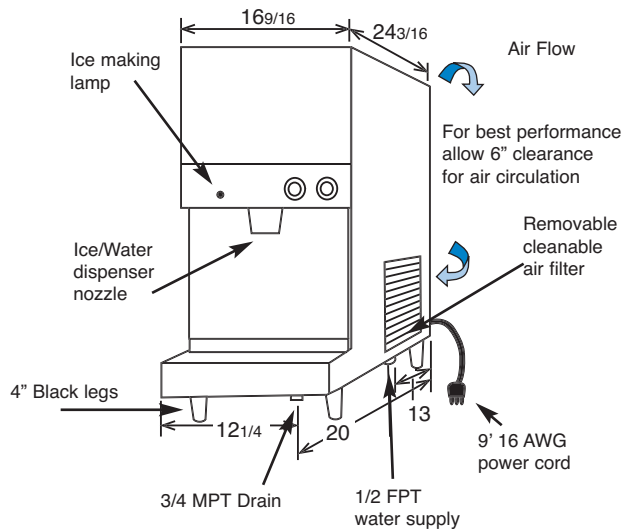

SD-270

ELECTRICAL & PLUMBING/DCM-270BAH

- 115V/60/1
- 15 amp cord connection
- 1/2" FPT Water Inlet
- 3/4" MPT Drain



© HOSHIZAKI AMERICA, INC.

618 Hwy. 74 S., Peachtree City, GA 30269

OPERATING LIMITS

- Ambient Temp Range 45 - 100°F
- Water Temp Range 45 - 90°F
- Water Pressure 10 - 113psig
- Voltage Range 104 - 127V

SERVICE

- Panels easily removed and all components accessible for service.
- Removable/cleanable air filter.

TEL 1-800-438-6087

FAX 1-800-345-1325

www.hoshizaki.com

Printed in U.S.A.

