

JETRAY

JT 30 THREE FLAVOR SERIES



FEATURES

- Visual display dispensing system creates impulse sales
- Interchangeable three and five gallon bowls (11 and 19 liter) can mix and match to meet variable product demand
- JWT 300...are available in any combination of one, two or three in-bowl whippers are available to serve a variety of whipped and non-carbonated beverages
- Unique pinch tube system dispenses all types of beverages, including those with heavy pulp
- Constant recirculation of beverage keeps drinks chilled and fresh
- No downtime. Any one bowl can be removed and sanitized while the other two operate
- Easy cleaning and maintenance
- Backed by a worldwide service network

Distributed By:
Commercial Refrigeration Service, Inc.
<http://www.JetsprayParts.COM>
<http://www.IceCubes.NET>
toll free (866) Ice Maker
(623) 869-8881



VISUAL DISPLAY DISPENSER



JT 30 THREE FLAVOR SERIES

SPECIFICATIONS

DESCRIPTION

Model	JT 30	JT30-W25 (Export)	JWT 303	JWT303-W25 (Export)
Volts	115V 60 Hz	220/240V 50 Hz	115V 60 Hz	220/240V 50 Hz
Watts	1115	1115	1700	1700
Amps	9.7	4.8	14.8	7.7

DISPENSER DIMENSIONS

	large bowls	small bowls
Height	26 ⁵ / ₈ " (68 cm)	23 ⁵ / ₈ " (60 cm)
Width	24 ¹ / ₂ " (41 cm)	16" (41 cm)
Depth	17" (43 cm)	17 (43 cm)

CABINETRY

White plastic and stainless steel

BEVERAGE BOWL & COVER

Transparent, virtually unbreakable LEXAN® resin. Bowls available in 3-gallon and liter markings with U.S. gallon and liter markings. JWT300 only available in 5 gallon

BEVERAGE CAPACITY

Large.....Approx 15 U.S. gallons (57.0 liters)
Small.....Approx 9 U.S. gallons (34.0 liters)

REFRIGERATION

Jet Spray 1/3 H.P. hermetically sealed system R134a

PACKAGING

Packed in 4 cartons, 1 for base and 3 for bowls

NET WEIGHT

JT SERIES	JWT SERIES
68 lbs. (30.9 kg)	77 lbs. (35.0 kg)

SHIPPING WEIGHT

83 lbs. (37.7 kg)	90 lbs. (40.9 kg)
-------------------	-------------------

AGENCY LISTINGS



ACCESSORIES



- Circulator adds flexibility for products not suited for spraying. Replace spray system with easy-to-insert device.
- Locking device prevents unauthorized use of dispenser when unattended.
- "Non-cup contact" push handle replaces the standard handle to meet all hygiene and sanitary requirements.
- 4" (10.2 cm) Extension legs available where required.

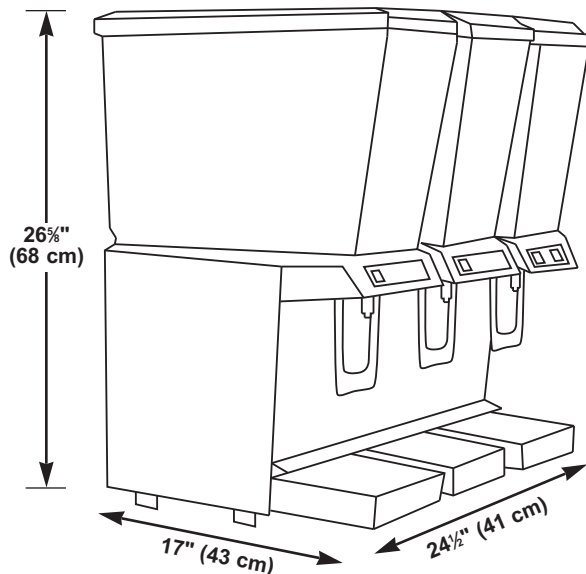

Distributed By:
Commercial Refrigeration Service, Inc.
<http://www.JetsprayParts.COM>
<http://www.IceCubes.NET>
toll free (866) Ice Maker
(623) 869-8881



For more information or to place an order, contact your sales representative or authorized distributor.

IMI CORNELIUS FOODSERVICE GROUP

One Cornelius Place
Anoka, MN 55303-6234
Tel: 1-888-248-5568 / 1-630-539-5050
Fax 1-800-344-3801 / 1-630-539-6960