



IMI CORNELIUS INC.  
[www.cornelius.com](http://www.cornelius.com)

---

## Nordic Hotel Dispenser Model CHD22 /CHD30 Installation and Service Manual



**Distributed By:**  
**Commercial Refrigeration Service, Inc.**  
**WWW.866IceMakers.COM**  
**866-IceMakers**  
**623-869-8881**



Publication Number: 631806053  
Revision Date: September 1, 2007  
Revision: A

Visit the IMI Cornelius web site at [www.cornelius.com](http://www.cornelius.com) for all your Literature needs.



To the owner or user: This product manual is a source of information about the installation, start up, cleaning, maintenance and repair of the product.

### **Table of Contents**

Introduction	Page 1
General Description	Page 2
Specification/Limitations	Page 5
Product Description	Page 6
Unpacking	Page 7
Installation-Plumbing	Page 8
Installation-Electrical and Ice Machine Assembly	Page 9
Final Check List/Initial Start Up	Page 10
Dispenser Use	Page 11
General Care and Cleaning	Page 12
Maintenance	Page 14
Adjustments	Page 15
Service Diagnosis	Page 16
Wiring Diagram-115 volt 60Hz. Basic and Water Station	Page 17
Wiring Diagram-Coin Mechanism	Page 18
Wiring Diagram-230 volt, 50HZ basic	Page 19

E-Mail: [tech.service@Cornelius.com](mailto:tech.service@Cornelius.com)

Website : [www.cornelius.com](http://www.cornelius.com)

Telephone Number

800-238-3600 All Departments

Any Service communication must include:

- Model Number
- Serial number
- A detailed explanation of the problem

**Keep this manual for future reference.**

**Cornelius icemakers and dispensers are not approved for outdoor installation.**

**WARNING: Always disconnect electrical power and shut off water supply whenever maintenance or repairs are performed on the ice machine and related equipment.**

**CAUTION: Always wear protective eyewear whenever maintenance or repairs are performed on the ice machine and related equipment.**

**The CHD22/CHD30 Service Parts Manual is available separately,  
Part Number 631806054**

The CHD22 is a 22 inch wide hotel/motel cubed ice dispenser. It is designed to use a Cornelius CcM0322 or CCM522 cube ice machine as the source for ice.

The CHD30\* is a 30 inch wide version of the CHD22 and is designed to use Cornelius CCM0330 through CCM0530 cubers as its source of ice. **Note: 22 inch wide ice machines are not for use on the 30 inch wide dispensers.**

\*Higher capacity cubers, CCM0630, CCM0830 and CCM1030 may also be used, but they require 230-volt power.

**Basic Operation:**

Ice from the cuber falls into the insulated hopper, where it is stored until needed. When a user pushes the dispense chute a rotating wheel scoops the ice up to the top front of the hopper where there is an outlet to the ice chute. Ice is directed into the users container.

**Flaked or nugget ice should not be used in these dispensers.  
Do not double stack cubers on these dispensers.  
Condensate drain pumps are not recommended for drainage.  
This is not a waterglass style dispenser.**

**Basic Specifications:**

<u>Model</u>	<u>Dimensions</u> W x H x D <u>With 6" Legs</u>	<u>Electrical</u>	<u>Model Description</u>	<u>Bin Storage Capacity</u> ARI
CHD22P1	22 x 53 x 33½	115/60/1	Basic 22" Model 60 Hz.	120 Lbs.
CHD22P5	22 x 53 x 33½	230/50/1	Basic 22" Model 50 Hz.	120 Lbs.

**Note:** The factory installed Water Dispenser and Coin /Token features are not available on the 22-inch wide Basic Push Button dispenser and are not available as a field installed kits.

CHD30P1	30 x 53 x 33½	115/60/1	Basic 30" Model 60 Hz	180 Lbs.
CHD30C1	30 x 53 x 33½	115/60/1	Coin/Token	180 Lbs.
CHD30P5	30 x 53 x 33½	230/50/1	Basic 30" Model 50 Hz.	180 Lbs.

**Note:** The factory installed Water Dispenser is not available on the 30-inch wide Basic Push Button dispenser and is not available as a field installed kit. The Coin/Token model is not available with a Water Filler and is not available as a field installed Water Filler Kit.

Basic models dispense ice when their chute is pushed and will continue to dispense ice until the chute is released or the bin is emptied. Coin/Token models require a coin or token first. Tokens are available from Cornelius, the part number for 500 tokens is 620204708. Water Dispenser models are basic models with a factory installed separate water dispenser.

**Bin Thermostats**

Bin Thermostats are not required in **CCM** series cubers on CHD22 or CHD30 Series Dispensers.

Dimensions

CHD22

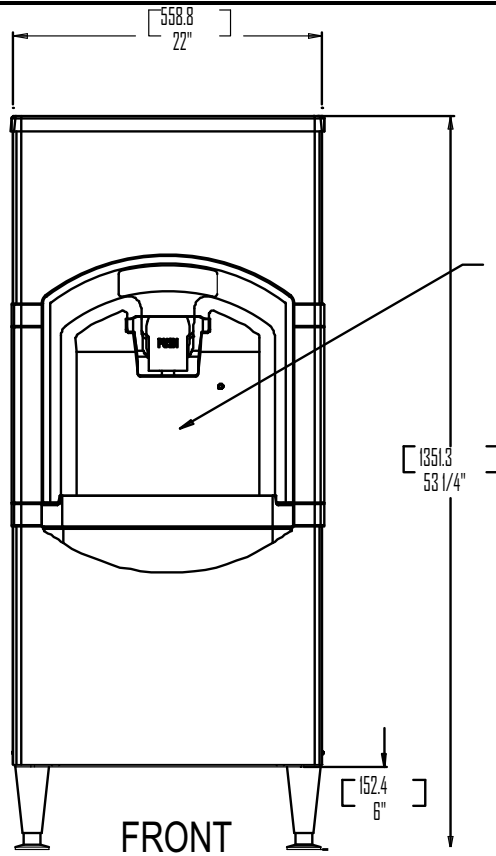

ICE FILL STATION  
8 3/4 [221.5] HIEGHT  
13 1/2 [342.9] WIDTH  
8 1/2 [215.9] DEPTH

[1351.3]  
53 1/4"

[152.4]  
6"

(2) 5/16-18 UNC  
ICE HEAD MOUNTING

[406.4]  
16"

[24.1]  
1"

Machine Support  
Screwed to Back  
Panel

POWER  
CORD

3/4 FPT  
DRAIN

[179.1]  
7"

[88.9]  
3 1/2"

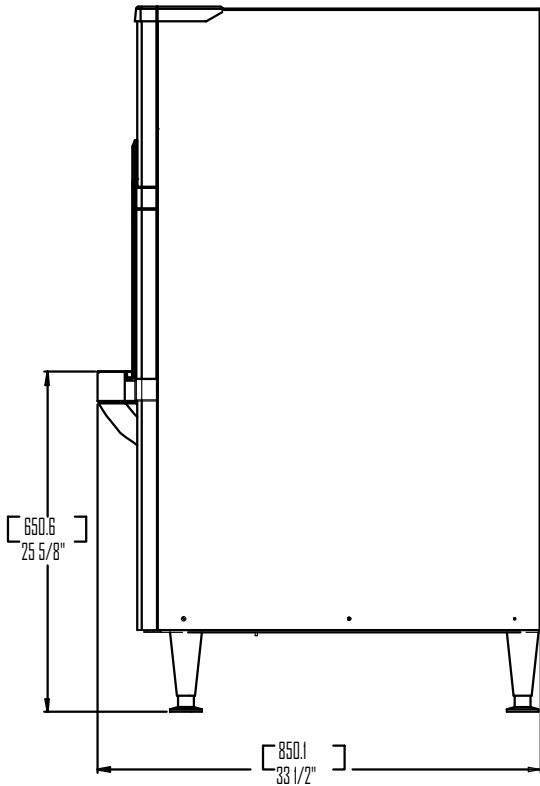

RIGHT SIDE

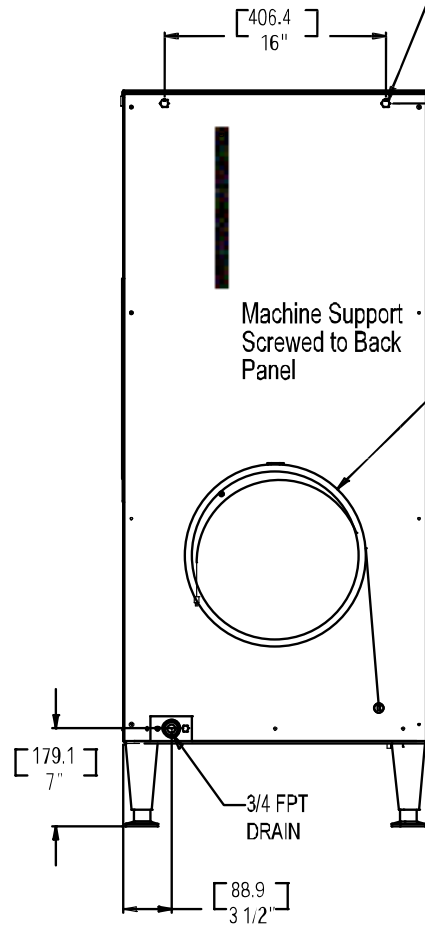

BACK

Dimensions

CHD30

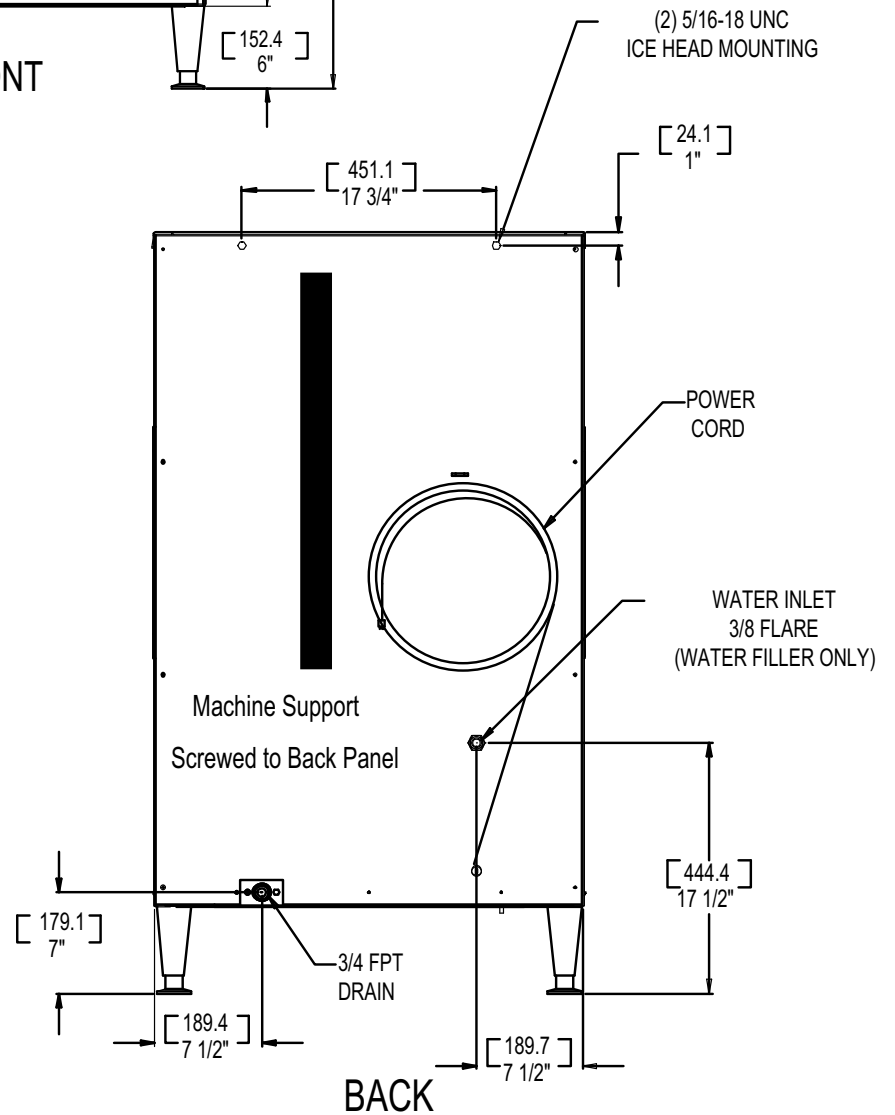
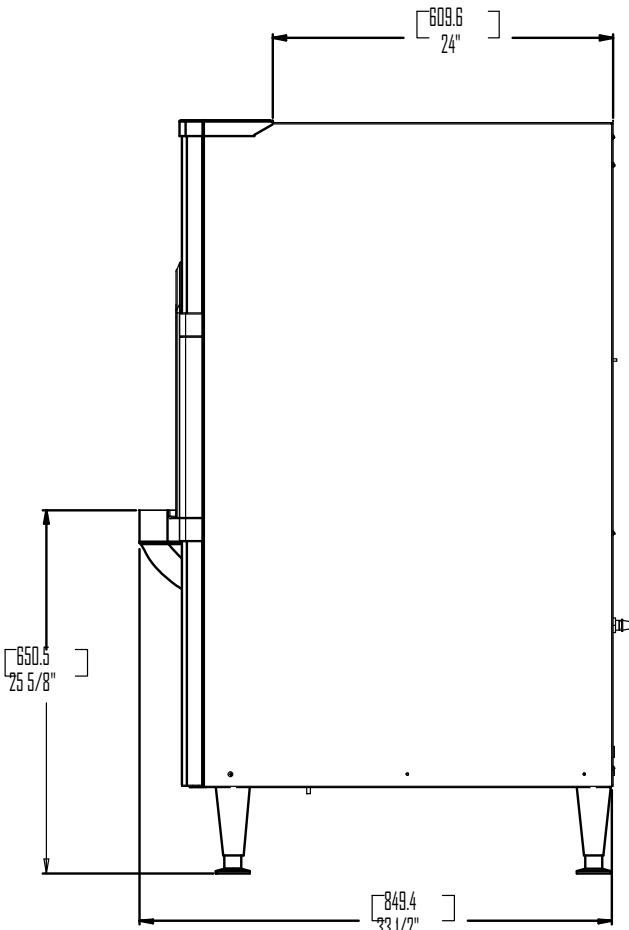
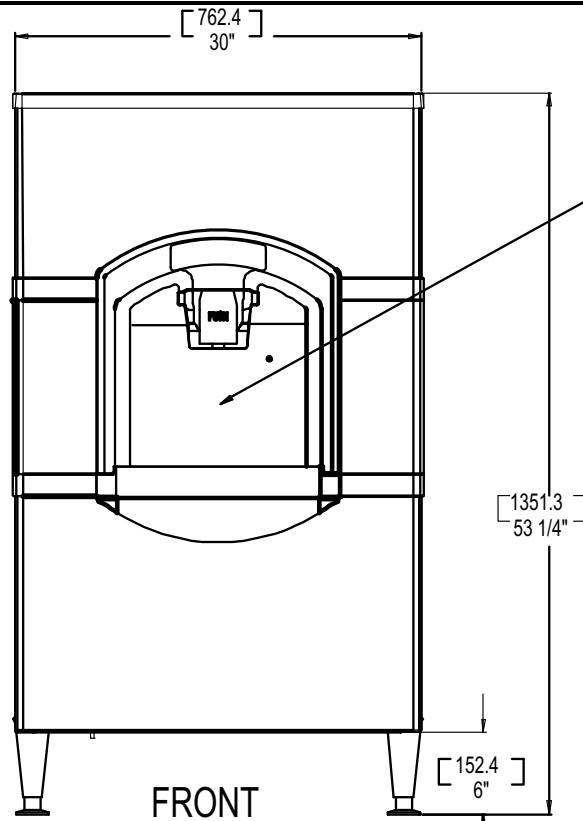

This dispenser is designed to be installed and operated **indoors, in a controlled environment**. It's minimum and maximum operating temperature limits are the same as those for the ice machine.

	<b>Minimum</b>	<b>Maximum</b>
<b>Air Temp</b>	50°F	100°F

Check the dispenser nameplate, located on the back of the cabinet for specific information. Cornelius reserves the right to make design changes and/or improvements at any time. Specifications and designs are subject to change without notice. Cornelius assumes no liability or responsibility of any kind for products manufactured by Cornelius that have been altered in any way, including the use of any parts and/or other components not specifically approved by Cornelius.

**Models:****CHD22**

The Basic version is constructed to deliver ice when the ice chute is pushed in, and it continues to vend ice as long as the ice chute is held in or until the bin is empty.

**CHD30**

There are two versions of the CHD30 dispensers: Basic and Coin/token. The Basic version is constructed to deliver ice when the ice chute is pushed in, and it continues to vend ice as long as the ice chute is held in or until the bin is empty.

The Coin/token version is designed to deliver ice after a coin or token is inserted into the coin slot AND then the ice chute is pushed in. Ice vending is limited to a preset time per coin or token use. Coins or tokens are collected in a coin box at the bottom of the dispenser. A keyed door allows access to the coin box without removing the front panel.

The Basic models of the CHD22 and CHD30 are available in 230 volt 50 Hz electrical for those countries with that type of electrical service.

**Kits: Bin tops and bin thermostats are not required. No other kits are available.**

**Distributed By:  
Commercial Refrigeration Service, Inc.  
WWW.866IceMakers.COM  
866-IceMakers  
623-869-8881**

All models consist of a plastic lined, insulated hopper mounted to a metal base. The hopper contains a 15 blade plastic dispense wheel and a stainless steel sweep arm. The top front of the hopper has a removable door to facilitate maintenance and cleaning of the hopper without removal of the ice machine.

The dispense wheel and sweep arm rotate when the ¼ HP dispense drive motor is actuated. The drive motor's actuation is controlled by the agitation timer or the vend switch. When the ice dispense chute is pushed back it moves the actuation lever up. The actuation lever releases the chute door and pushes the vend switch arm up. When the vend switch arm has moved a preset distance the vend switch contacts close, providing power to the dispense drive motor. Ice is delivered to the top end of the ice chute by the dispense wheel and it slides down the chute to the container below. The container rests on a grill, the grill's openings are over the ice catch pan, and any spilled ice goes there. The grill has a flange at the front to help contain the ice if it spills during vending.

After the ice dispense chute is released, the ice chute door closes to stop ice flow. Ice in the chute will eventually melt. Melted ice water is routed to the drain through a hose attached to the bottom of the chute. Spilled ice is contained in an insulated ice catch pan. Melted ice water from the ice catch pan is routed to the drain. User debris is kept away from the drain in the catch pan by a slotted shield.

The side and front exterior panels are stainless steel. The vending area and top panel are made of plastic.

**Coin / Token Model**

The coin op model's operation is identical to the basic operation described above with the exception that no power is provided to the vend switch until the coin mechanism has activated the vend timer. The vend timer then allows the vend switch to be activated for a set time, during that time the user must dispense the ice. A green "ready" light over the vending area will glow when the vend timer is armed and ready for dispensing.

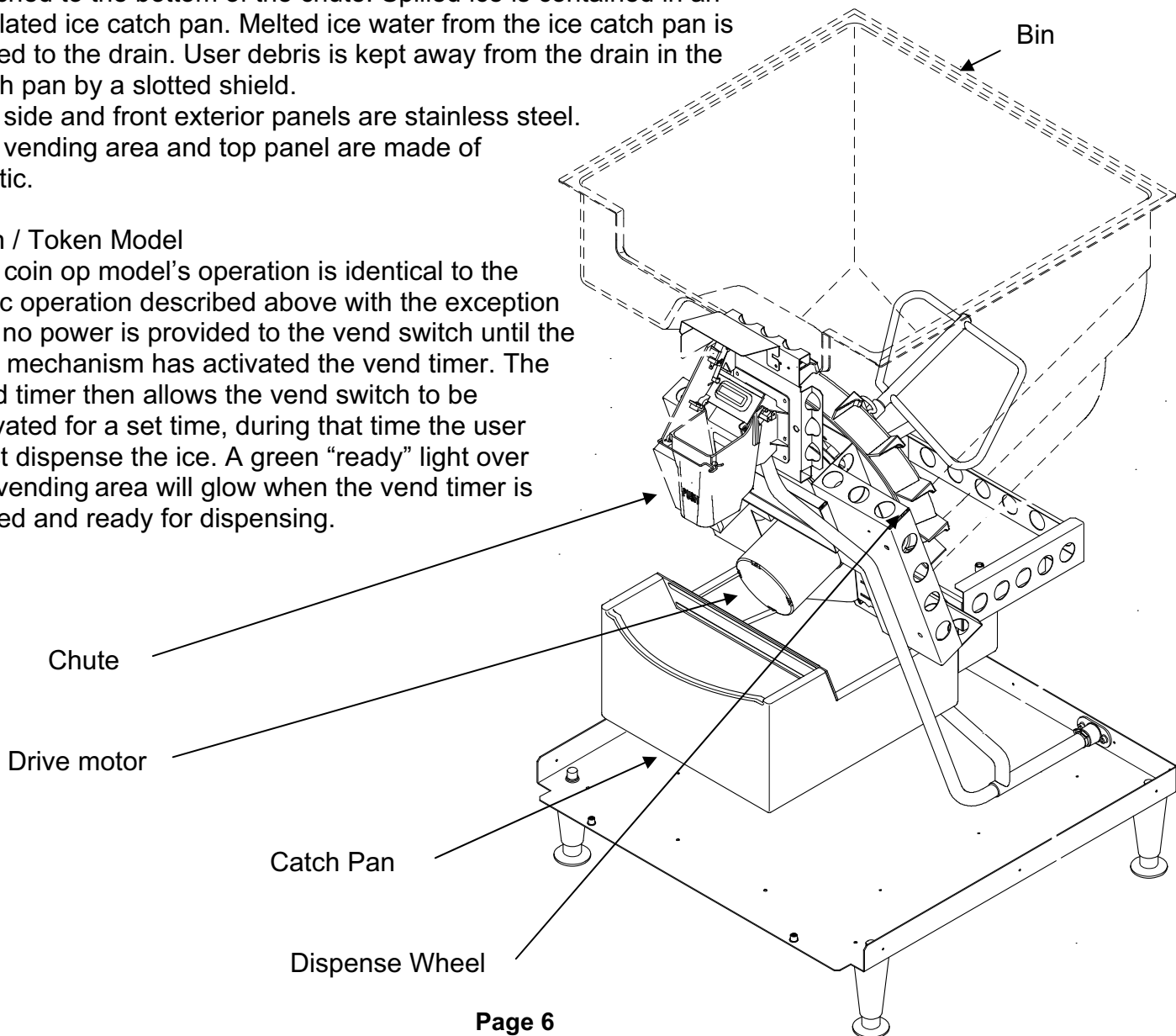

After removing the carton, check for the loose-shipped parts packed in the storage bin. The parts will include a carton with four legs. Remove the leg carton and any other loose-shipped items.

To remove the skid, place part of the carton behind the unit and tip the unit on its back. Remove the bolts holding the skid to the base of the CHD dispenser and separate the skid from the unit.

Install the legs into the base of the unit, using the holes where the skid bolts were. Turn the leg leveler part of the legs in all the way, adjust them later after the unit is in its final installed position.

Move the dispenser to an upright position and set it in the location where it will be installed. Note where the drain lines and electrical connections will be made.

### Front Panel Removal

The front panel rests on the base and is located with pins that stick up from the base. It is retained to the side panels by strikes and latches. The top panel keeps the front panel from moving forward.

To remove:

1. Disconnect electrical power.
2. Remove the two screws holding the top panel to the dispenser. Lift the top panel up and off the dispenser.
3. Pull the top edge of the front panel forward until the two snaps disengage.
  - If the unit is a coin op model, reach behind the front panel and disconnect the coin mechanism harness from the front panel.
  - If the unit is a water dispenser model, reach behind the front panel and shut off the water supply valve to the water faucet. Then disconnect the water line from the shut off valve.
4. Lift the front panel up and off the base.

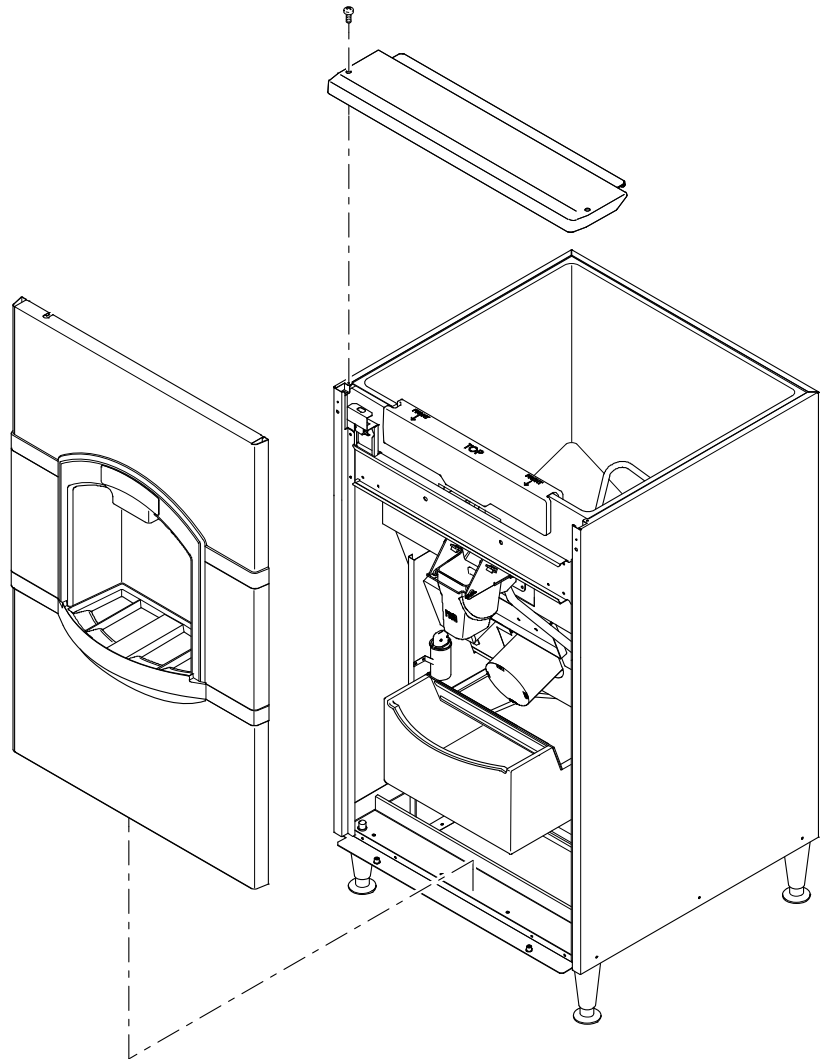

**Drain:**

All models of the dispenser have a 3/4" FPT drain fitting at the bottom of the back panel. Connect 3/4" rigid tubing to this connection, a vent is recommended for most installations. Route the drain tubing to the building drain.

---

**Note: Drain fitting material is plastic. If using copper, sweat the copper tube to copper fitting together before installing on the dispenser.**

**Note: Keep PVC solvent away from all plastic parts of the dispenser.**

---

**Follow all applicable plumbing codes.**

Because the drain tubing will be very cold, insulation is recommended for the tubing.

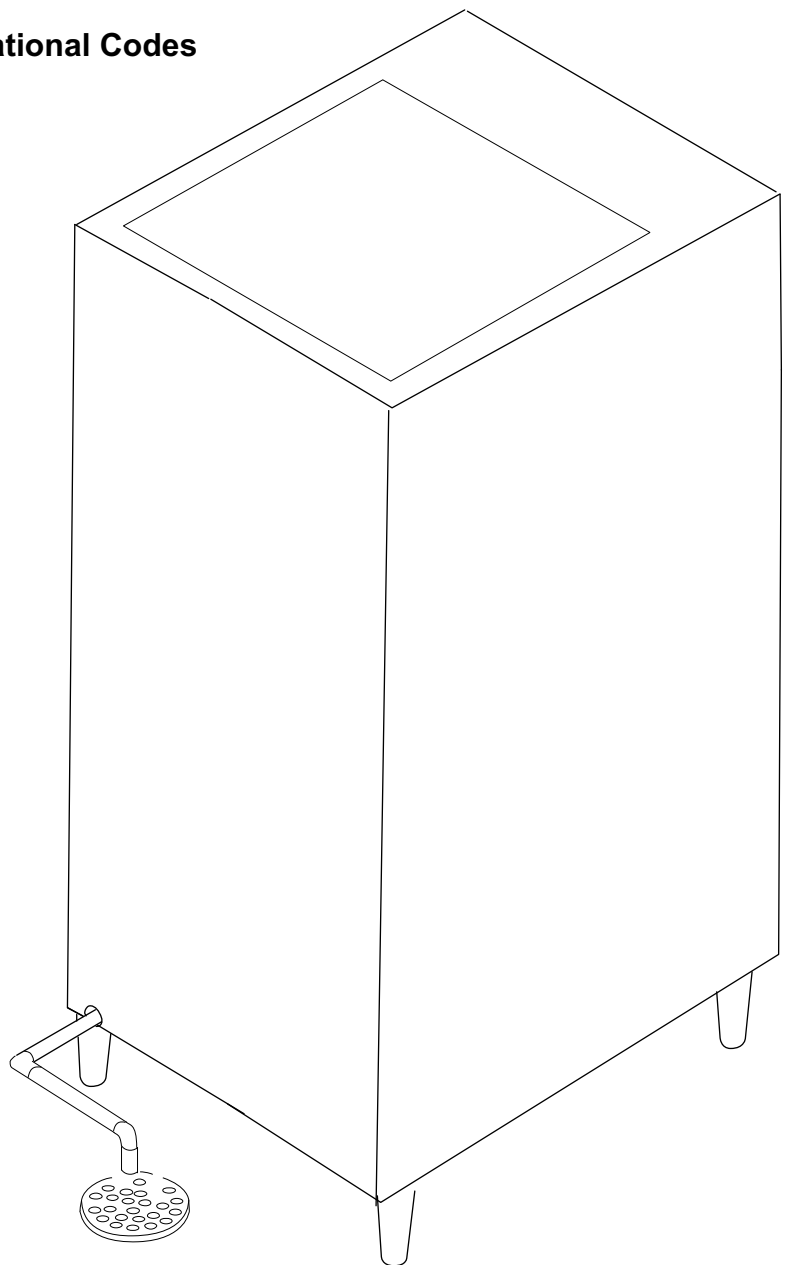
**Follow All Local, State and National Codes**

**Caution: Do not use a condensate pump in place of a floor drain.**

The dispenser is supplied with a power cord. Do not use with an extension cord. The unit must be plugged into a properly grounded outlet. The dispenser must be installed so that it is a separate piece of equipment from the ice machine. The drains and electrical supply must be separate.

**Follow All Local, State and National Codes**

**Ice Machine**

All models: Place the dispenser in the location where it will be used. Level the top edge of the dispenser front to back and left to right.

**Sanitize the dispenser bin with a locally approved sanitizer.**  
See page 12.

Place the ice machine on the dispenser and secure it to the dispenser with the hardware and bracket from the dispenser. Install it according to the instructions in the manual included with the ice machine.

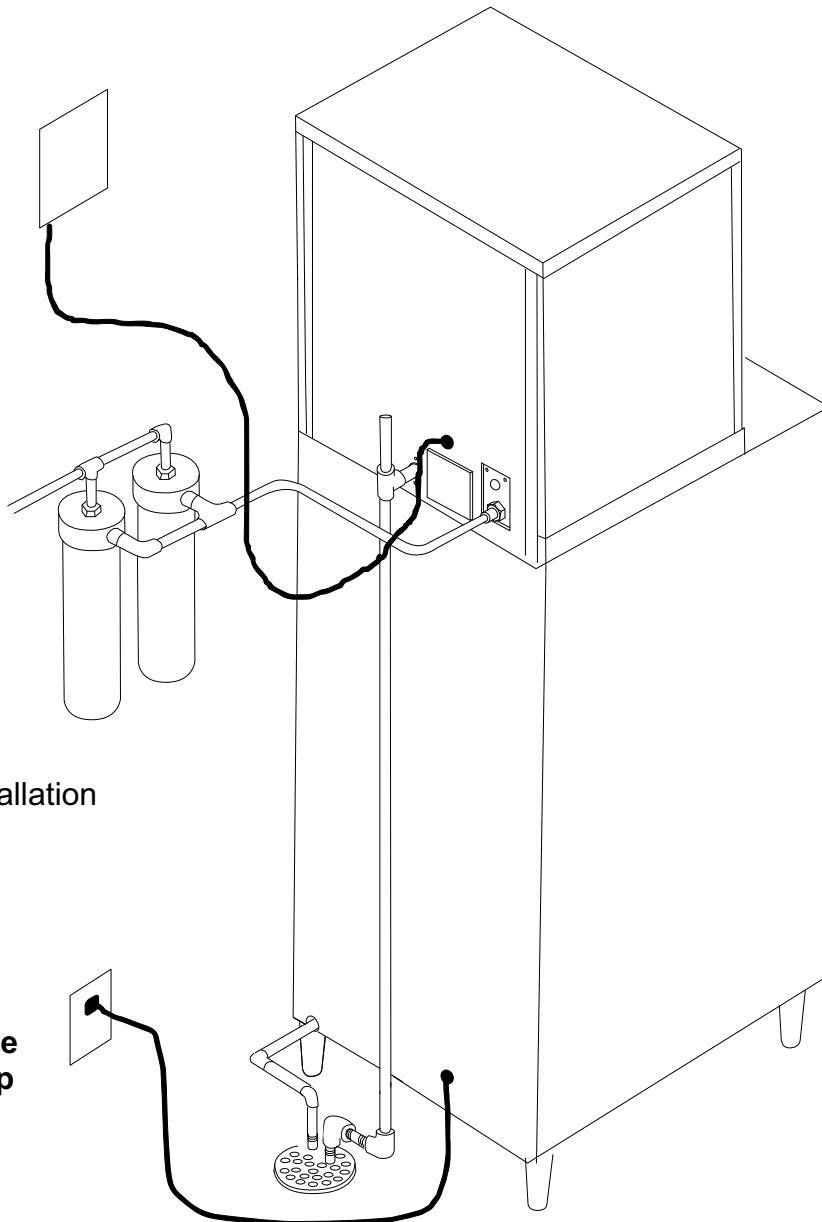
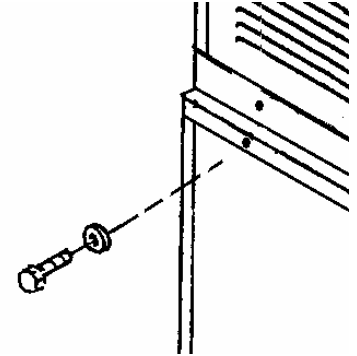

Rear View of Typical Installation

**Caution: Do not use a condensate pump in place of a floor drain.**

Route drains separately to a floor drain.

1. Check that electrical power has been supplied.
2. Check that a drain, separate from the ice machine, insulated and made of rigid tubing, has been connected to the dispenser.
3. Check that the ice machine has been properly installed per the ice machines installation directions.
4. Check that the ice machine/dispenser assembly is level front to back and left to right.
5. Check that the coin box access key, if used, is available.

**To Start:**

1. Connect electrical power. The dispensing system will cycle on for a few seconds.
2. Go thru ice machine start up procedures. Let the ice machine make two harvests.
3. Push the ice chute in.
4. Dispense wheel turns.
5. Ice will be dispensed from ice chute.
6. Fill out the warranty registration form and place it in the mail.
7. Give the operator any keys and the instructions on the operation and maintenance of the product.

Check that the operator knows who to call for service, and has the product/service manuals for the machines.

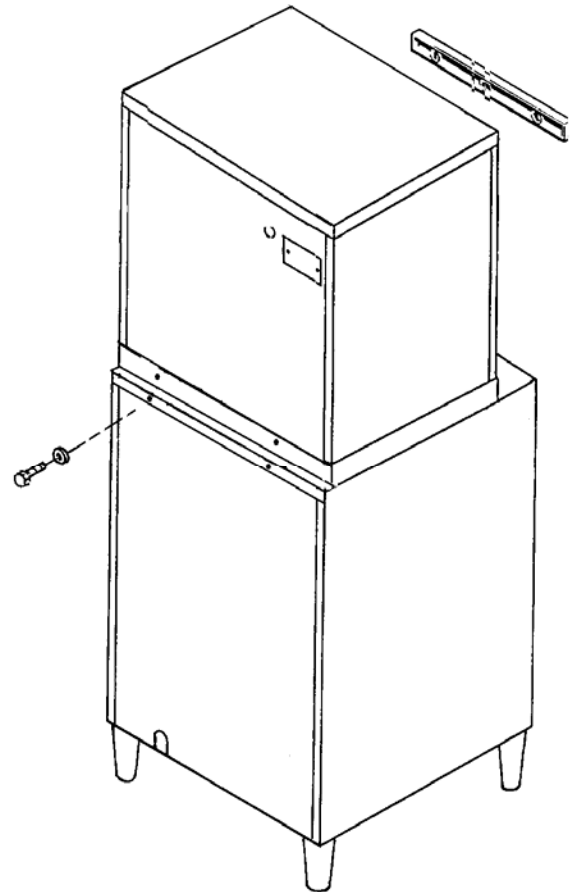

**Electrical Sequence**

Pushing the ice chute closes a contact to the gear motor.

The gearmotor will have power and the dispenser will continue to operate as long as the ice chute is pushed in. This model also has an agitation cycle of 3 seconds every 6 hours. Since the ice chute is not pushed in during agitation no ice is dispensed.

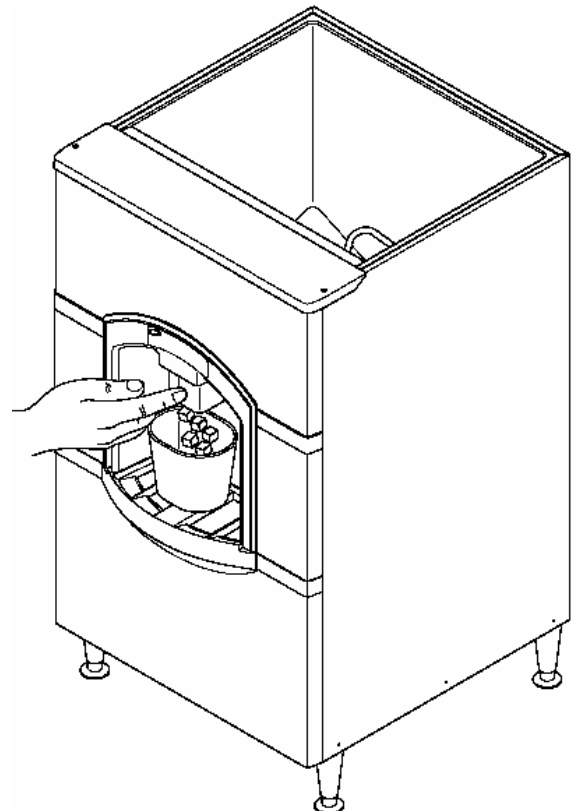

**Basic Model**

After the ice machine has operated for a few hours, the CHD dispenser can be used. Pushing the ice chute back will activate the dispense mechanism and ice will drop out of the chute into the user's container.

**Coin/Token Model Operation**

Without activation the dispenser will not dispense ice when the ice chute is depressed.

To activate the dispense system, the user must insert a quarter or a token in the coin mechanism. If the quarter or token is accepted, the Ready Light above the ice chute glows green, indicating that ice can now be dispensed. The dispense system will allow ice vending for a pre-set time. Once activated, pushing the chute in (like the basic model) causes the ice to vend. At the end of the pre-set time, vending stops.

**Free Vend:** There is a free vend switch inside the unit, switch it to ON to bypass the coin mechanism and vend ice anytime the chute is pushed back.

When switched to Free Vend the Ready light will be ON.

When switching from Free Vend to Coin / Token operation the Ready light will be ON for a few seconds.

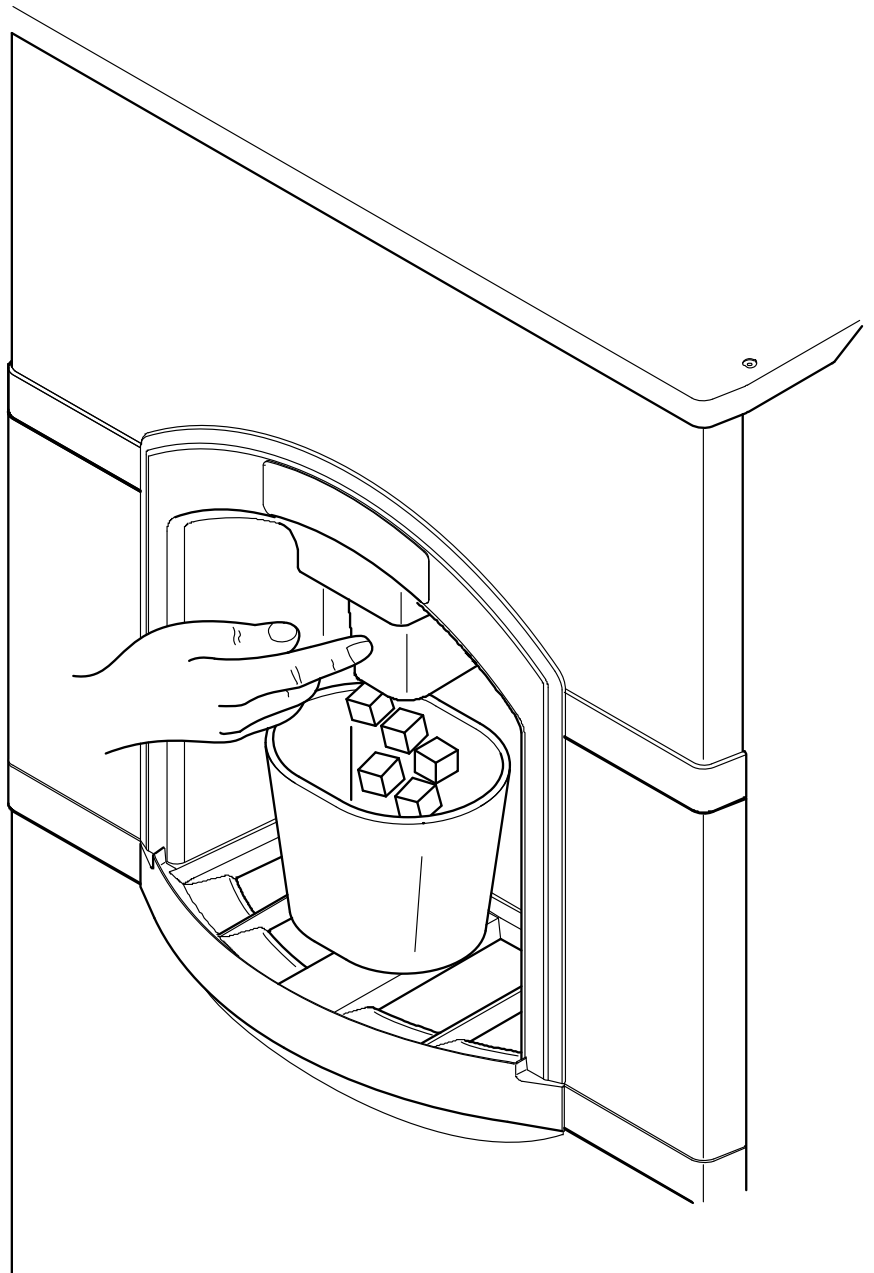

Periodically inspect and clean the ice dispenser to keep it operating at peak performance. Wash the outside of the dispenser with warm water and soap. Rinse off and wipe dry.

### Cleaning and Sanitizing of the Ice Storage Bin:

The minerals, chlorine and other impurities in the water are rejected from the water during the freeze cycle of the ice machine. These minerals will collect in the storage bin. The ice storage bin should be cleaned and sanitized every 90 days.

1. Remove all of the ice stored inside the dispenser bin and shut off the ice maker.
2. Disconnect electrical power to the dispenser.
3. Remove top front panel (in front of ice machine).
4. Remove the front panel.
5. Remove the deflector (30 inch wide only).
6. Lift up and remove the access door at the front of the bin
7. Reach into the opening, locate the hair pin and pull it out of the drive shaft. (Ref. Page 13)
8. Pull the sweep arm off the drive shaft and remove it from the dispenser.
9. Pull the dispense wheel off the drive shaft and remove it from the dispenser.
10. Mix a solution of 5 ounces of ice machine cleaner to 1 gallon of warm (95°F-115°F) water. Wash the entire bin area and the delivery area. Use a clean brush or cloth.

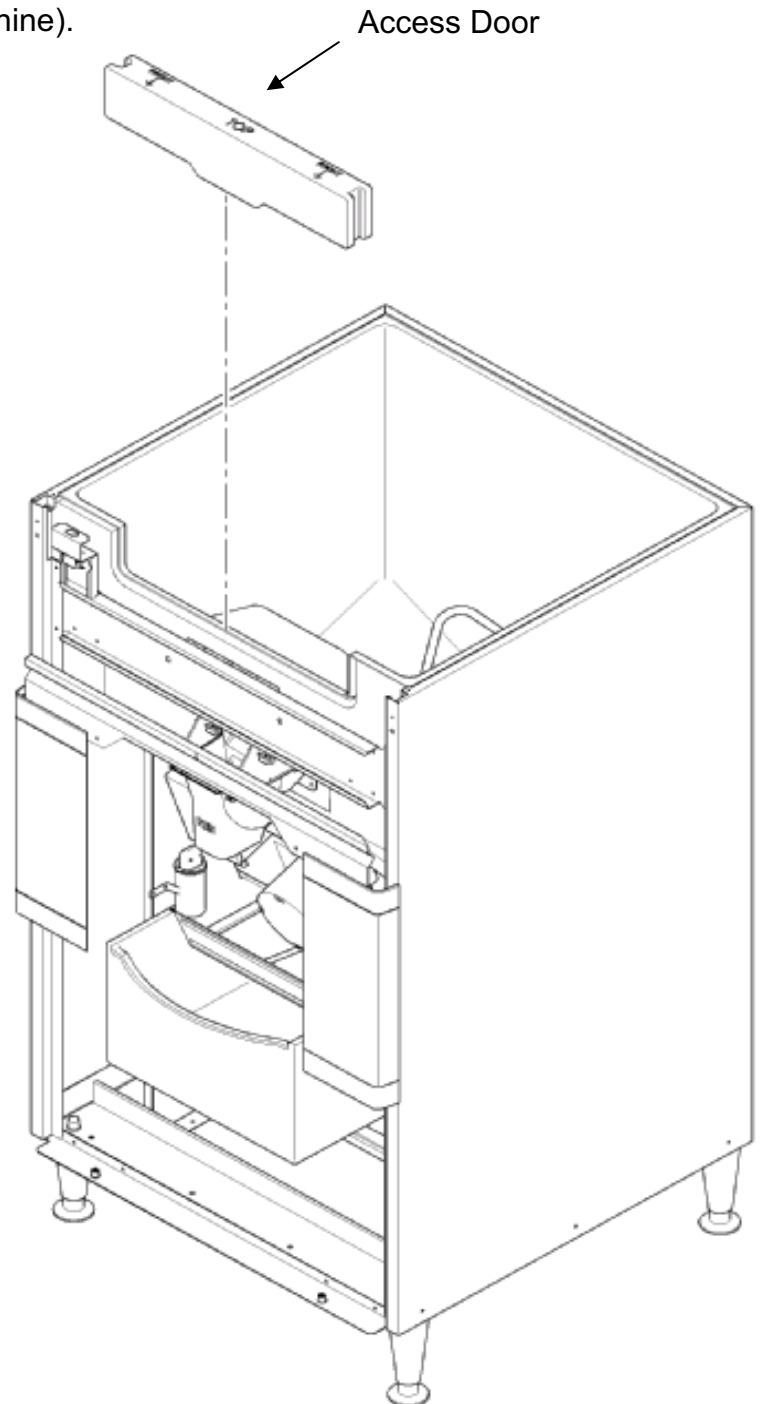

10. Rinse all areas washed with clean, fresh water
11. Using the ice machine cleaning solution, clean the ice grill, sink, sweep arm and dispense wheel. Rinse these parts with clean fresh water.
12. To sanitize: Use a locally approved sanitizer per label instruction. Wash all interior surfaces, the sweep arm and dispense wheel with the sanitizer solution. Use a clean cloth.
13. Allow the parts to air dry.
14. Reassemble wheel and sweep arm onto drive shaft. Be sure to reinsert hairpin.
15. Replace all panels.
16. Reconnect power, be sure ice machine is switched back on.

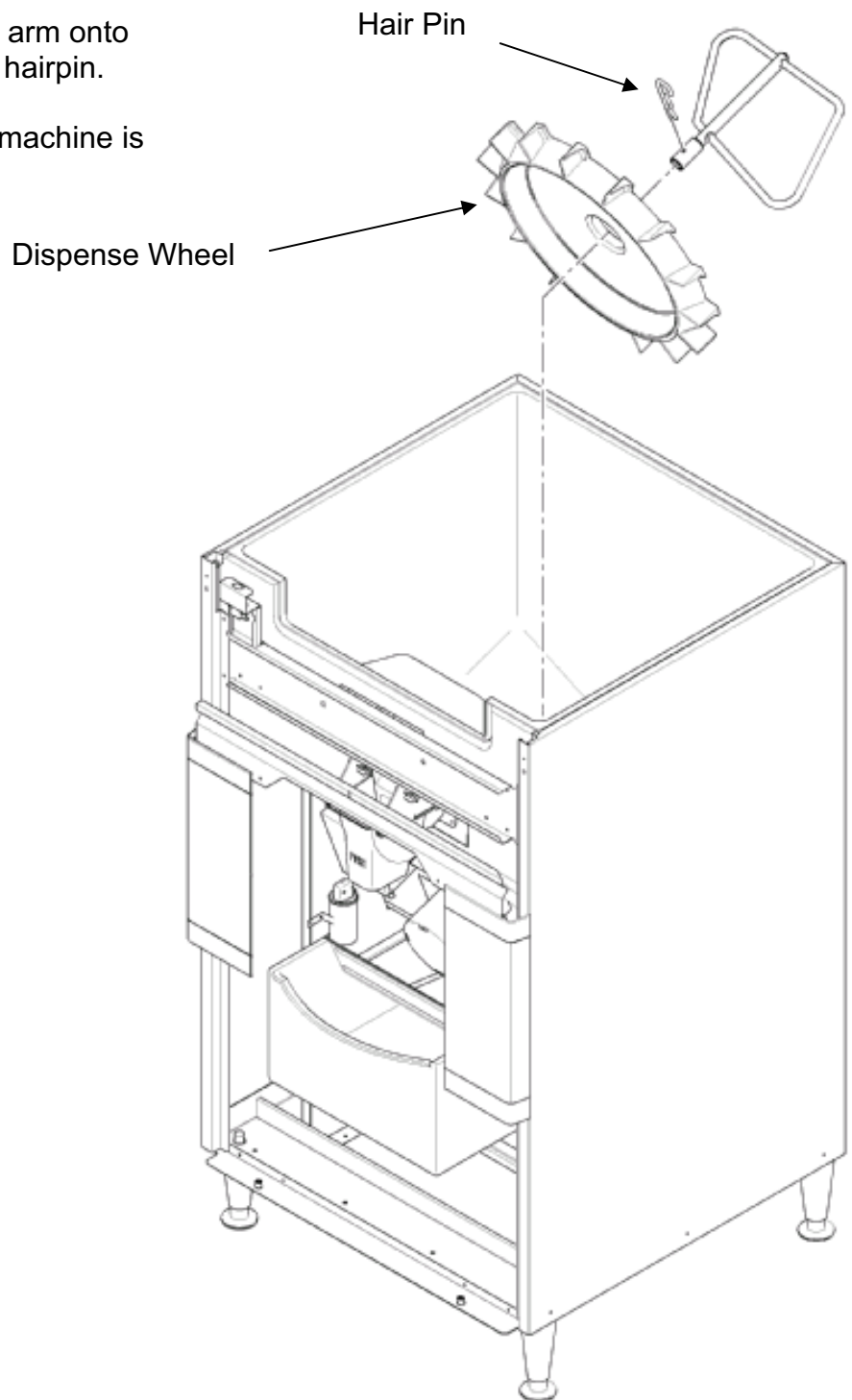

Spilled ice and user debris will collect in the ice catch pan, located just below the sink grill. Occasionally the debris will need to be removed and the drain flushed out to prevent water back ups.

Note: Failure to clean out the ice catch pan will likely result in a water leak, one that is NOT covered by warranty.

### To clean out the ice catch pan:

1. Disconnect electrical power.
2. Remove the two screws holding the top panel to the dispenser. Lift the top panel up and off the dispenser.
3. Pull the top edge of the front panel forward until the two snaps disengage.  
If the unit is a coin op model, reach behind the front panel and disconnect the coin mechanism harness from the front panel.  
If the unit is a water dispenser model, reach behind the front panel and shut off the water supply valve to the water faucet. Then disconnect the water line from the shut off valve.
4. Remove the front panel.
5. Pull the ice catch pan forward a few inches until the drain hose can be reached.
6. Pull the drain hose from the ice catch pan.
7. Slide the ice catch pan out of the ice dispenser and clear it of any debris. Wash out the drain.
8. Return the ice catch pan to its normal position.
9. Re-attach the drain hose.
10. Reassemble and connect power.

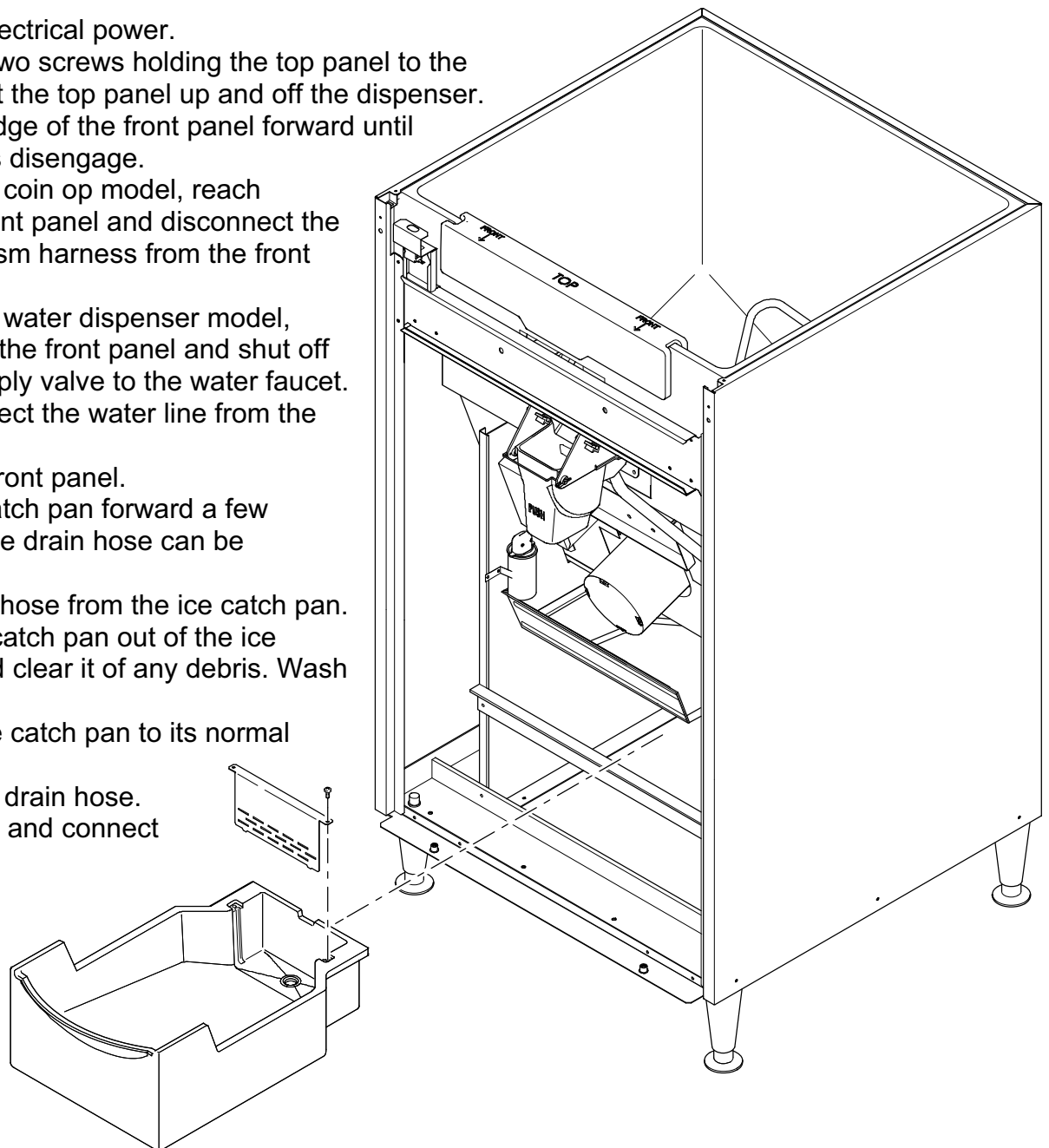

The dispenser is preset at the factory. Adjustments are rarely needed.

**Agitation Time Recommendations:**

The standard time is 3 seconds on every 6 hours. Adjust to agitate more frequently if the unit is installed in a low temperature environment. However, if the ice being dispensed is in small crushed pieces, adjust to agitate less frequently.



**Coin or Token Operation**

The standard time for vending is pre set at 20 seconds on the Vend Ready Timer. This includes time allowed for vending and customer activation. If necessary, adjust this timer to a higher number to deliver more ice, or a smaller number for less ice.

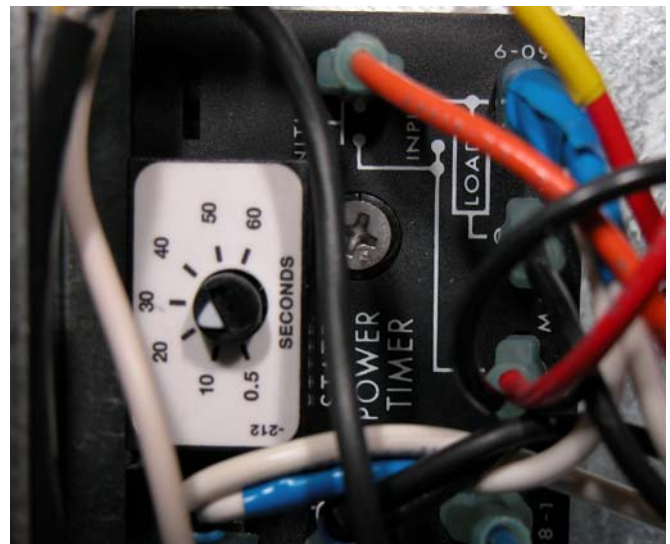

**Distributed By:**  
**Commercial Refrigeration Service, Inc.**  
**WWW.866IceMakers.COM**  
**866-IceMakers**  
**623-869-8881**

Symptom	Probable Cause	Possible Fix
No ice is dispensed Basic Model	No power to dispenser.	Check for proper power. Is dispenser plugged in?
	No ice.	Check ice machine.
	Vend switch does not close.	Check vend switch. Check chute for proper motion.
	Interlock switch open.	Check interlock switch, be sure top panel is in place.
	Drive motor windings open.	Check drive motor.
	Drive gears failed.	Check gear reducer.
No ice is dispensed Coin Op Model	Same as above plus coin switch does not close	Check coin switch.
	Vend timer does not work.	Connect power to post 6 of coin mech timer, timer should activate, ready light should be ON and pushing the chute should start the gear motor, If not replace the vend timer.
Only dispenser small amounts of ice.	Sweep arm damaged.	Check/replace sweep arm.
No water dispensed, Water Dispenser model	Water shut off.	Check water supply to unit, check shutoff valve inside cabinet.
Water leak	Drain is plugged	Check drain for restriction
	Ice catch pan has overfilled	Remove excess ice.
	Ice catch pan screened plugged	Clean screen
	Seal between ice machine and dispenser leaking	Remove ice machine and replace gasket tape.
Water drip from spout	Some dripping is normal, but if severe-	Check spout drain for restriction.

Wiring Diagram, 115 volt, 60Hz.

ALL CONTROLS SHOWN IN  
NORMAL ICE DISPENSING MODE

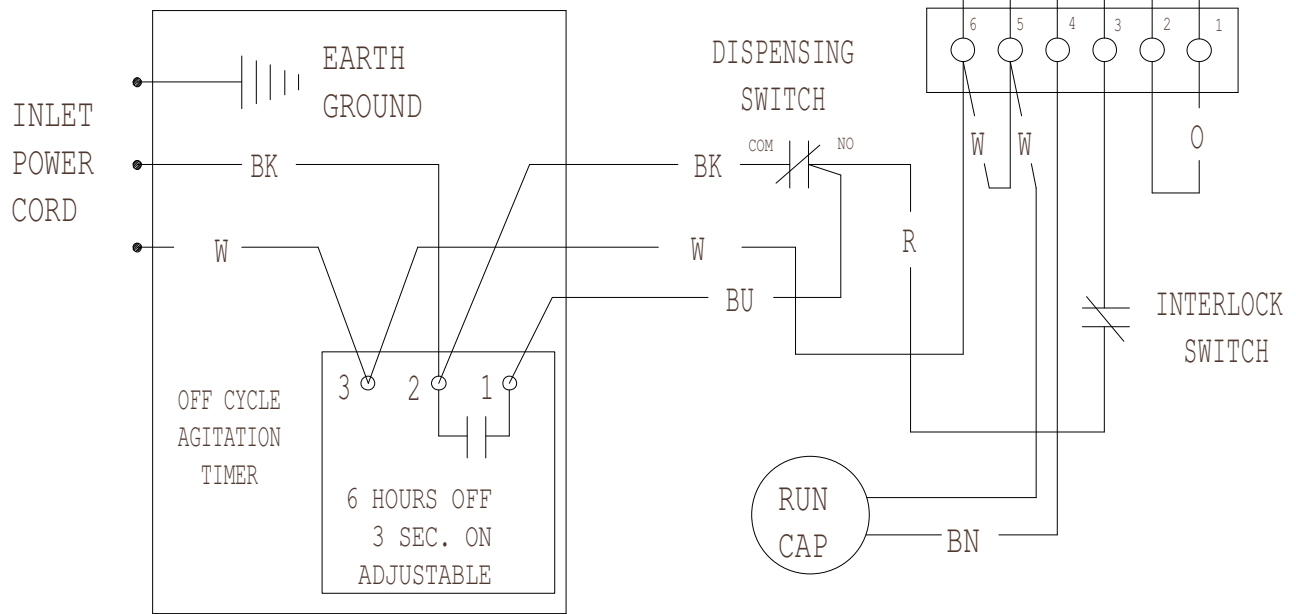

USE COPPER CONDUCTORS ONLY

Wiring Diagram for Coin Mechanism Model

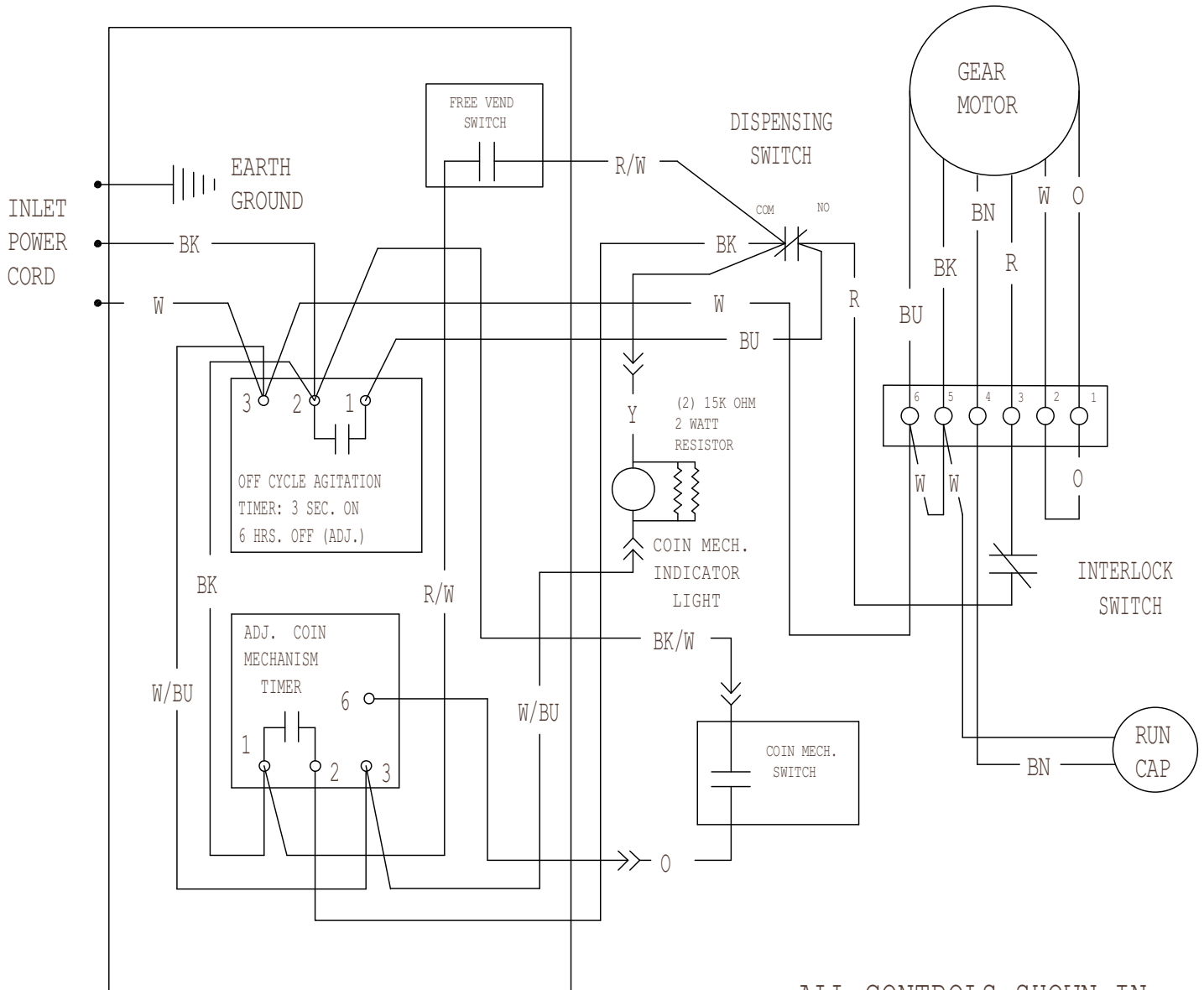

USE COPPER CONDUCTORS ONLY

ALL CONTROLS SHOWN IN  
NORMAL ICE DISPENSING MODE

Wiring Diagram 230 volt, 50 Hz.

ALL CONTROLS SHOWN IN  
NORMAL ICE DISPENSING MODE

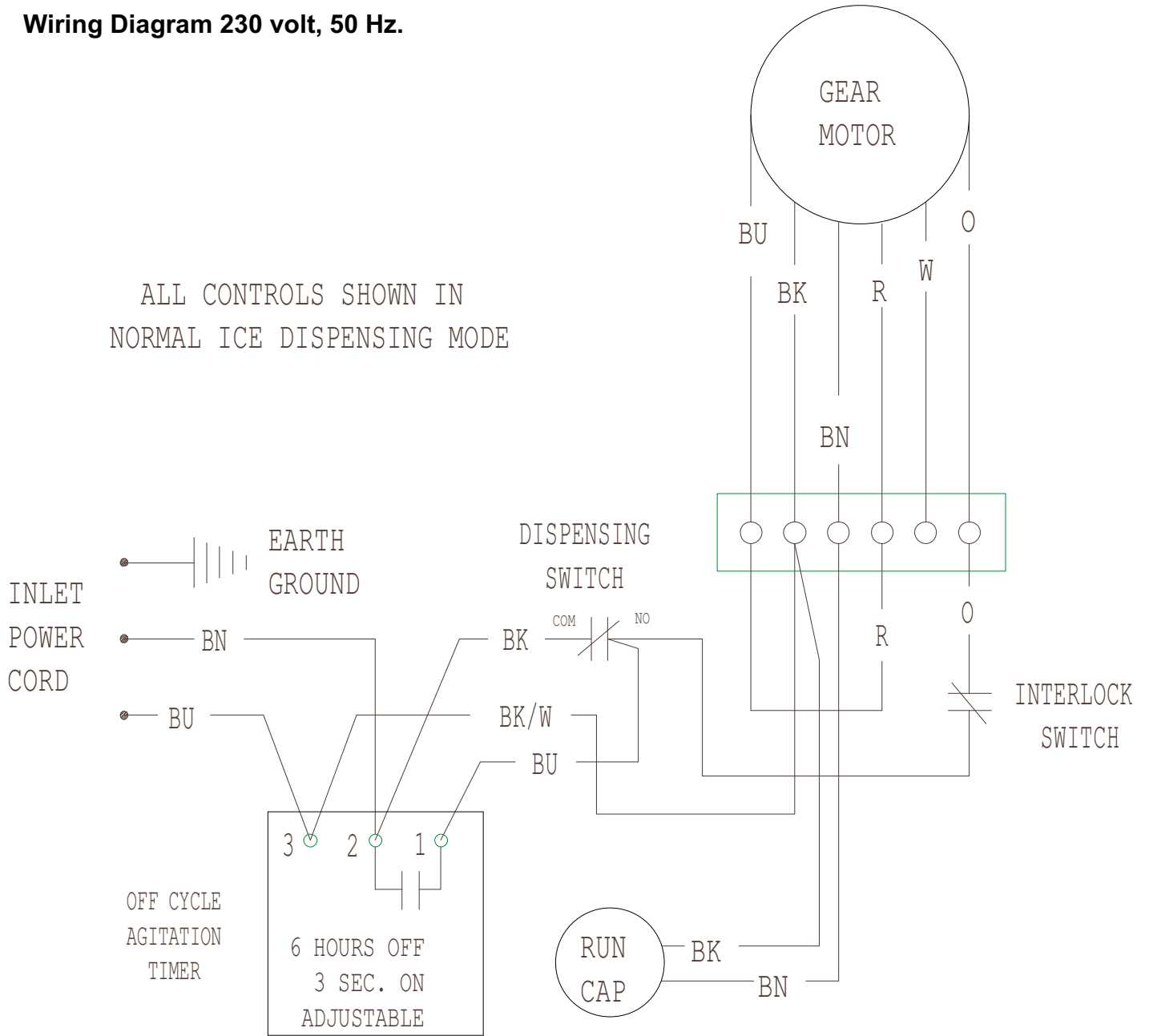

USE COPPER CONDUCTORS ONLY

**Distributed By:**  
**Commercial Refrigeration Service, Inc.**  
**WWW.866IceMakers.COM**  
**866-IceMakers**  
**623-869-8881**