



IMI CORNELIUS INC.
www.cornelius.com

Nordic Model CCM1530 Service Parts Manual



Distributed By:
Commercial Refrigeration Service, Inc.
WWW.866IceMakers.COM
866-IceMakers
623-869-8881



Publication Number: 631806062
Revision Date: November 1, 2007
Revision: A

Visit the IMI Cornelius web site at www.cornelius.com for all your Literature needs.

This parts list contains the service parts available for the CCM icemaker listed below.

CCM15301 Remote**

Check the model number on the data plate and refer to the correct listing for the specific component.

Check carefully that the correct part is identified and ordered.

Table of Contents	Page 1
Cabinet Exterior Panels	Page 2
Cabinet Breakdown	Page 3
Refrigeration System	Page 4
Evaporator and Components (Right Side)	Page 5
Evaporator and Components (Left Side)	Page 6
Control Box and Bin Switch Assembly	Page 7
Water Pump/Float Assembly	Page 8
Harvest Probe Assembly	Page 9
Remote Condenser RC15002	Page 10

E-Mail: [tech.service @cornelius.com](mailto:tech.service@cornelius.com)

Website: www.cornelius.com

Telephone Number
800-238-3600 All Departments

The CCU Series Service Manual is available seperately, Part Number 631806061

Note: Model Number Suffix Indicates Machine Voltage As Follows:

1=115/60/1

2=208-230/60/1

3=208-230/60/3

5=230/50/1

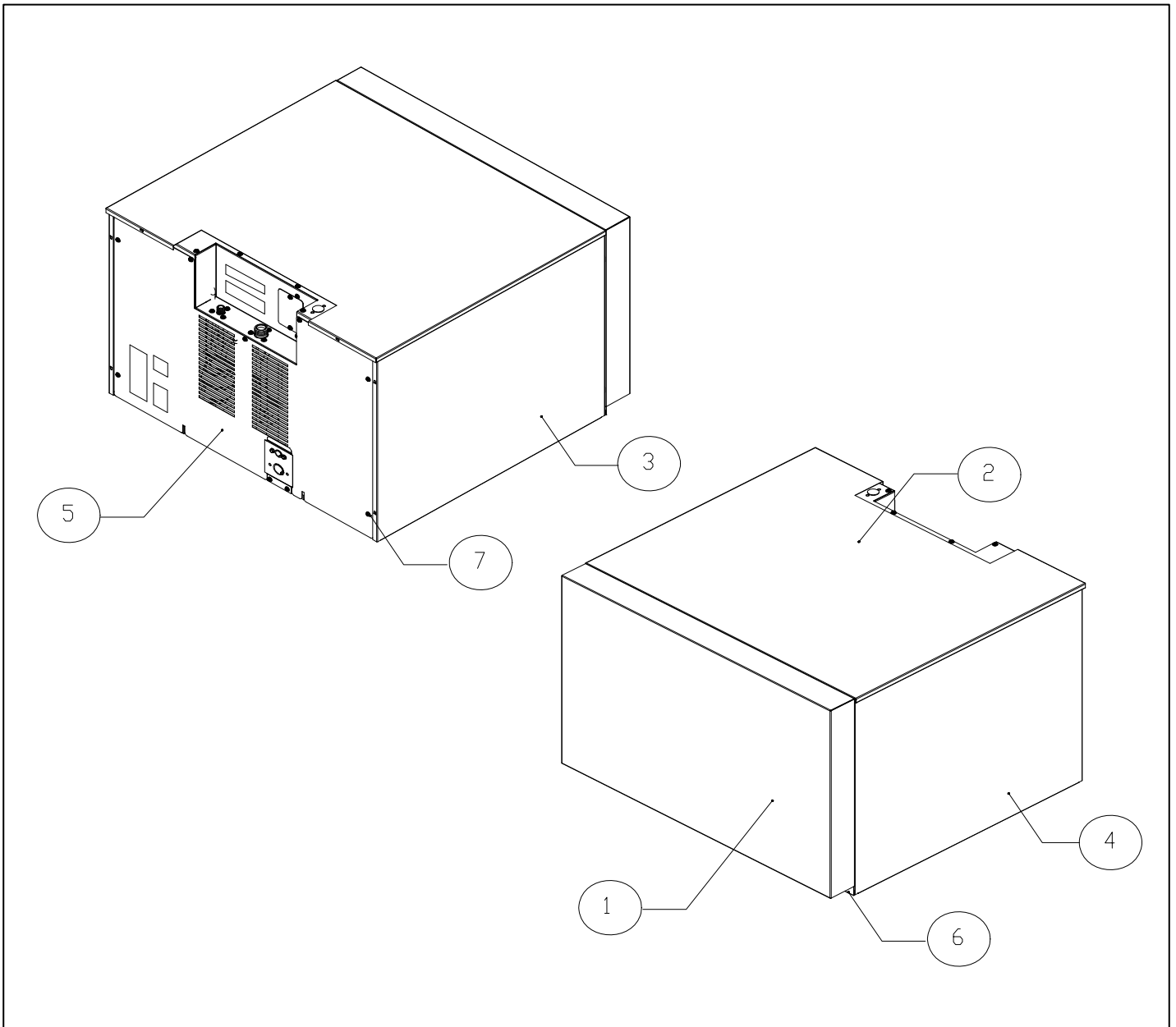

Item No.	Part Number	Description
1	620204806	Front Panel
2	620204394	Top Cover
3	620204807	L.H Side Panel
4	620204325	R.H Side Panel
5	620204805	Back Panel
6	620204445	Front Panel Screw
7	620204441	Rear Panel Screw

Distributed By:
Commercial Refrigeration Service, Inc.
WWW.866IceMakers.COM
866-IceMakers
623-869-8881

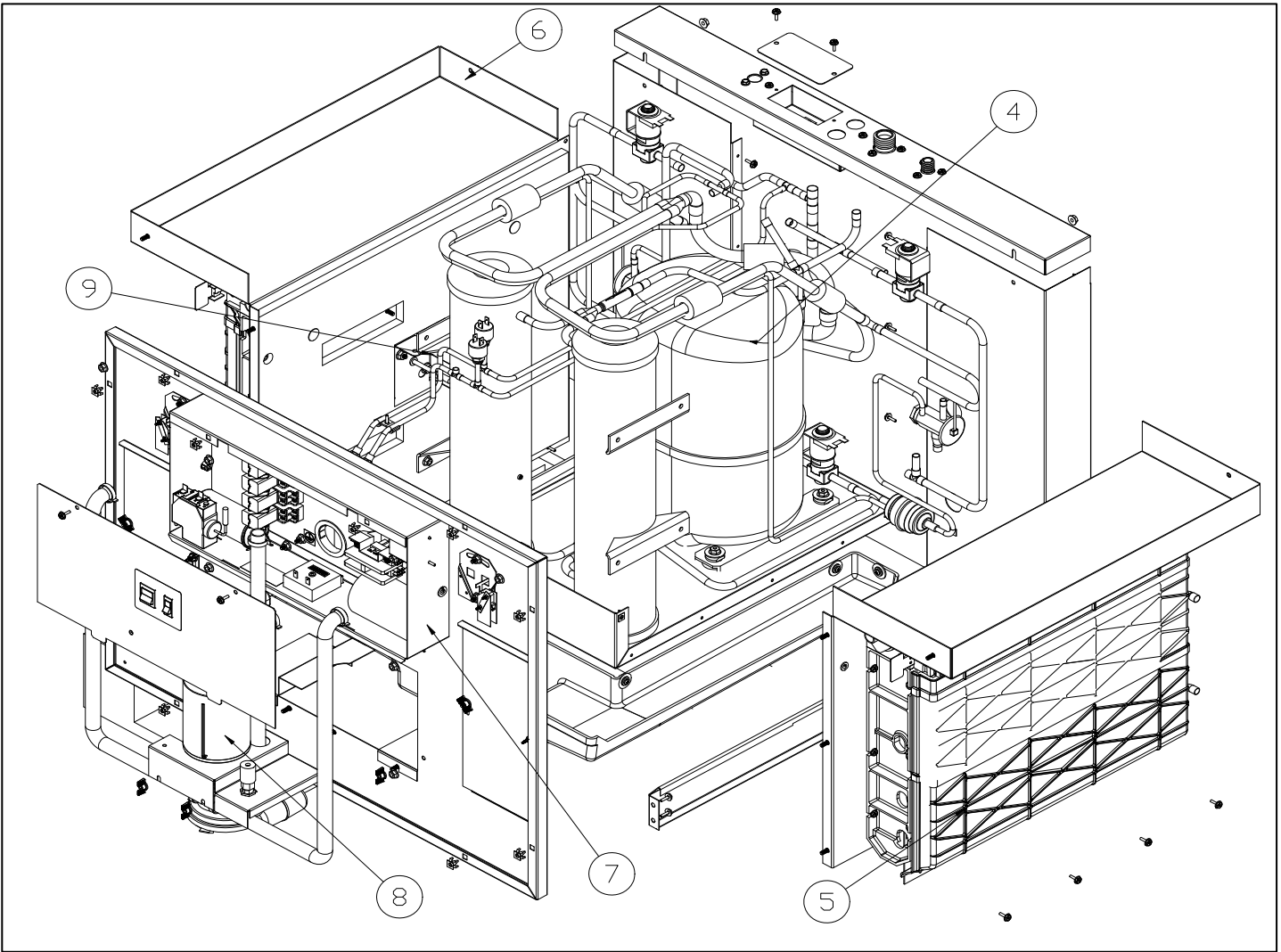

Item No.	Page Number	Description
4	Page No. 4	Cabinet Base
5	Page No. 5	Evaporator Assembly
6	Page No. 6	Evaporator Assembly
7	Page No. 7	Control Box and Bin Switch Assembly
8	Page No. 8	Pump Assembly
9	Page No. 9	Harvest Assist

Distributed By:
Commercial Refrigeration Service, Inc.
WWW.866IceMakers.COM
866-IceMakers
623-869-8881

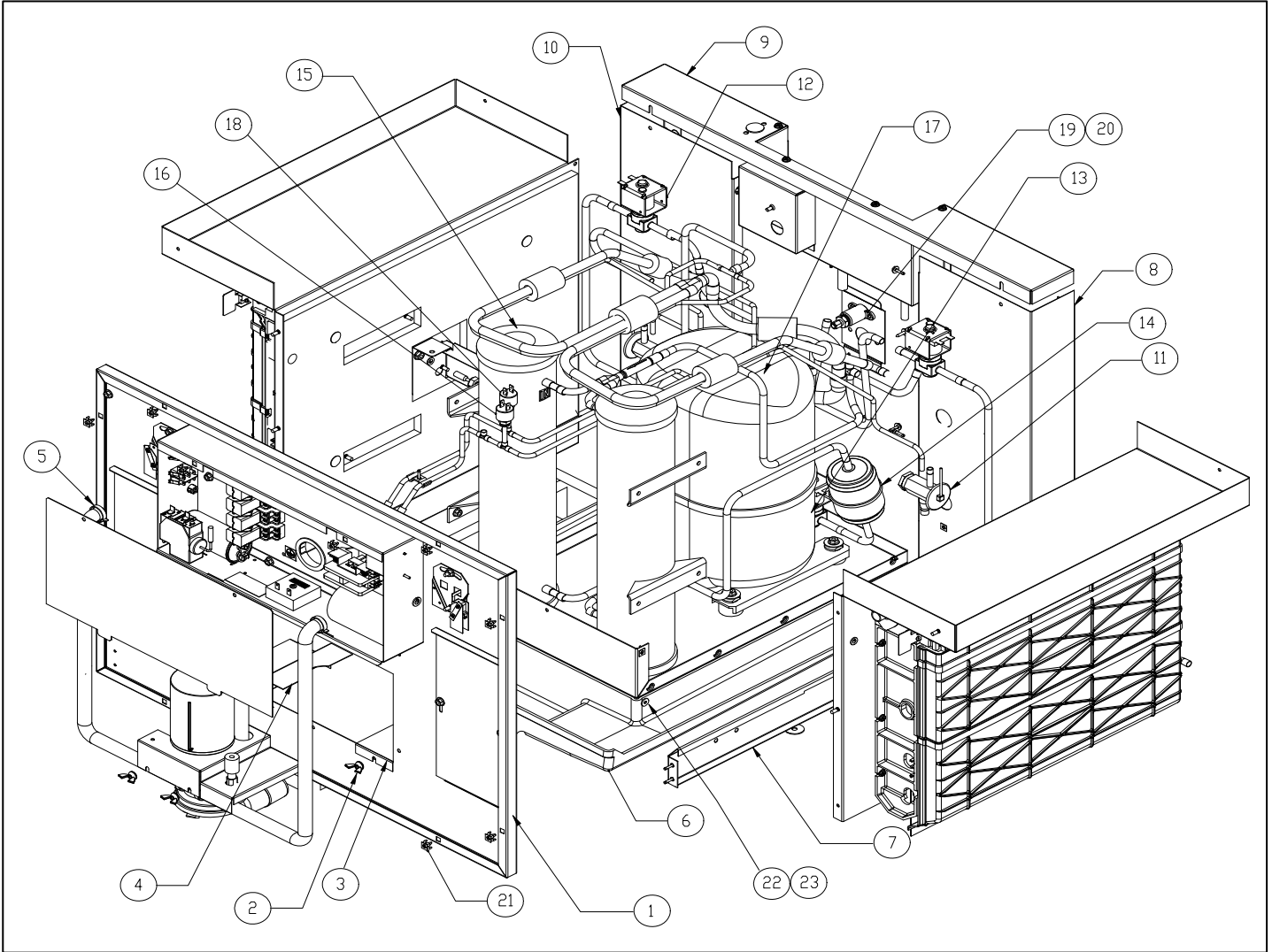

Item No.	Part Number	Description
1	620204803	Front Frame panel
2	620204459	Plastic Wing Nut
3	620204350	Water Pan Cover
4	620204353	Water Pan Cover
5	620204420	Hose Clamp
6	620204509	Water Pan
7	620204351	Ice Deflector
8	620204362	Rear Frame RH
9	620204804	Rear Brace
10	620204362	Rear Frame LH
11	620204617	Expansion Valve
12	620204611	Hot Gas Valve
	620204614	Hot Gas Valve Coil
13	620204612	Liquid Line Solenoid
	620204614	Liq. Line Sol. Coil

Item No.	Part Number	Description
14	620204602	Drier
15	620204622	Receiver
16	620204475	Pump Down Control
17	620204690	Compressor
18	620204474	High Pressure Control
19	620204530	Drop Adapter
20	620204533	Water Inlet Fitting
21	620204457	Plastic Nut
22	620204429	Flat Washer
23	620204443	Screw
N/A	620204813	Purge Drain Fitting

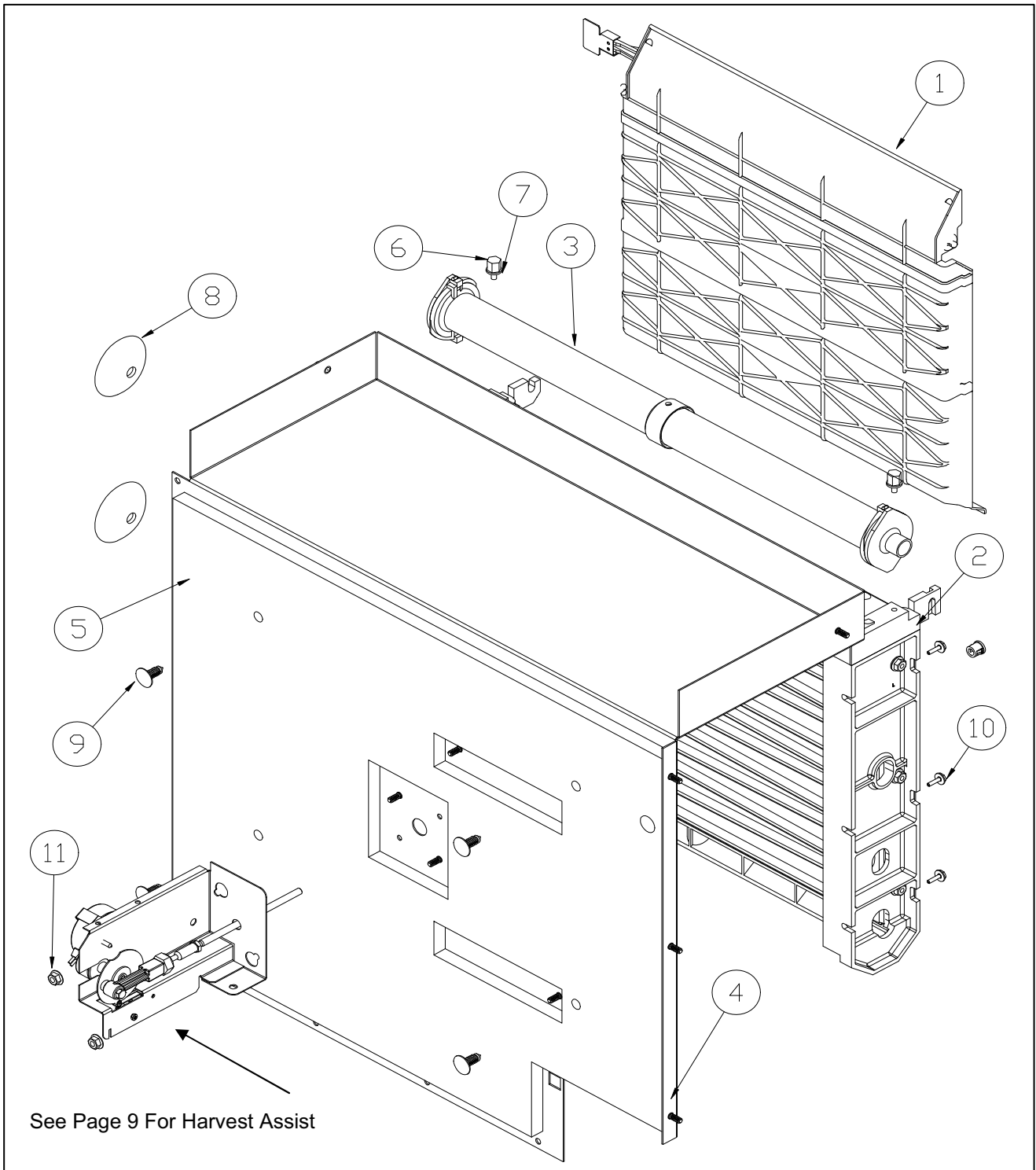

See Page 9 For Harvest Assist

Item No.	Part Number	Description
1	620204322	Splash Curtain RH
2	620204301	Evaporator Right Side--Half
2	620204300	Evaporator Right Side--Full
3	620204295	Water Distribution Tube
4	620204801	Frame Panel RH
5	620204802	Insulation, Side Panel
6	620204453	Thumb Screw

Item No.	Part Number	Description
7	620204429	Rubber Washer
8	620204498	Tube Washer
9	620204458	Clips
10	620204441	#10-16 X 1/2 Screw
11	620204449	#10-24 Flanged Locknut

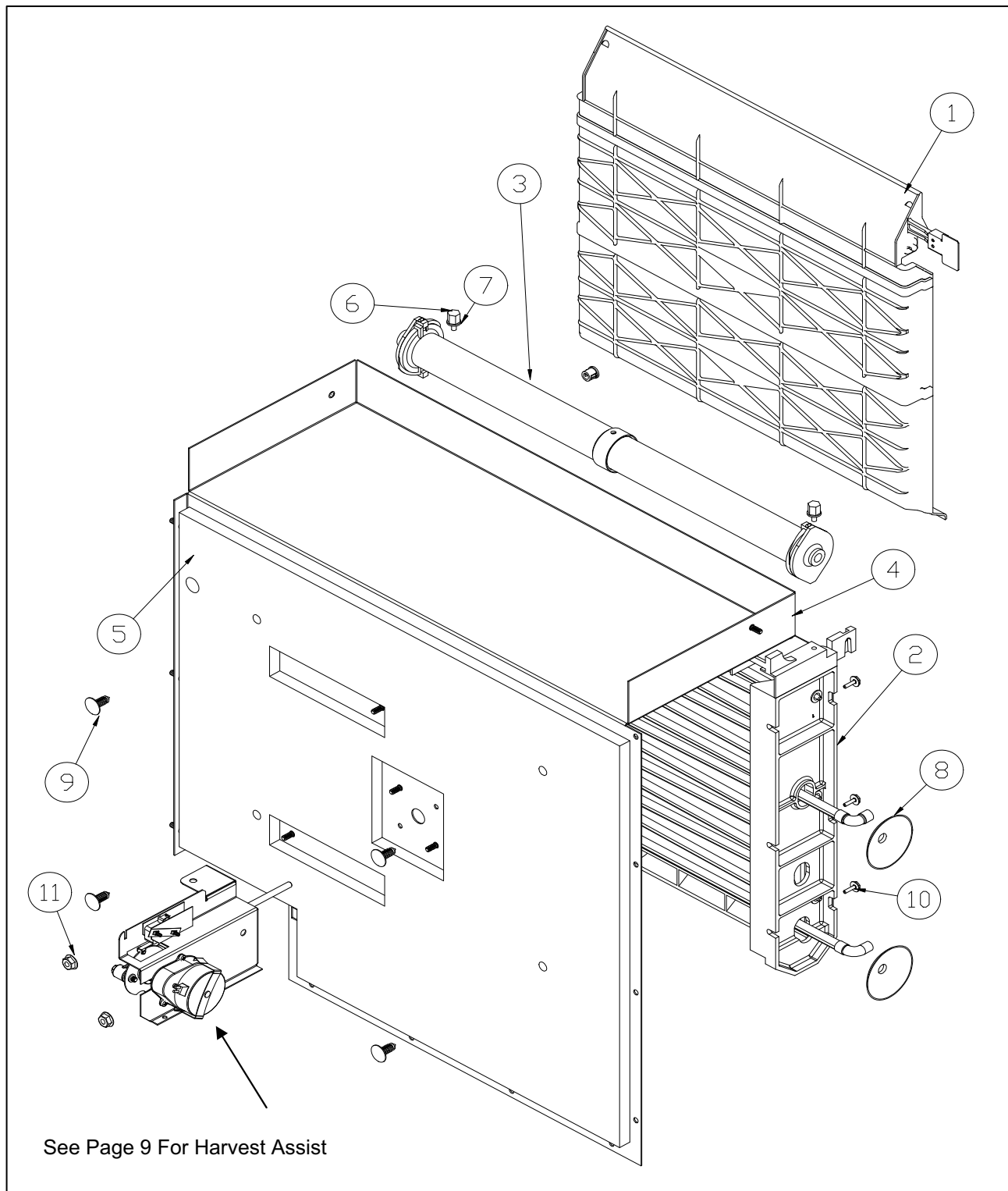

See Page 9 For Harvest Assist

Item No.	Part Number	Description
1	620204323	Splash Curtain LH
2	620204303	Evaporator Left Side--Half
2	620204302	Evaporator Left Side--Full
3	620204295	Water Distribution Tube
4	620204799	Frame Panel LH
5	620204800	Insulation, Side Panel
6	620204453	Thumb Screw

Item No.	Part Number	Description
7	620204429	Rubber Washer
8	620204498	Tube Washer
9	620204458	Clips
10	620204441	#10-16 X 1/2 Screw
11	620204449	#10-24 Flanged Locknut

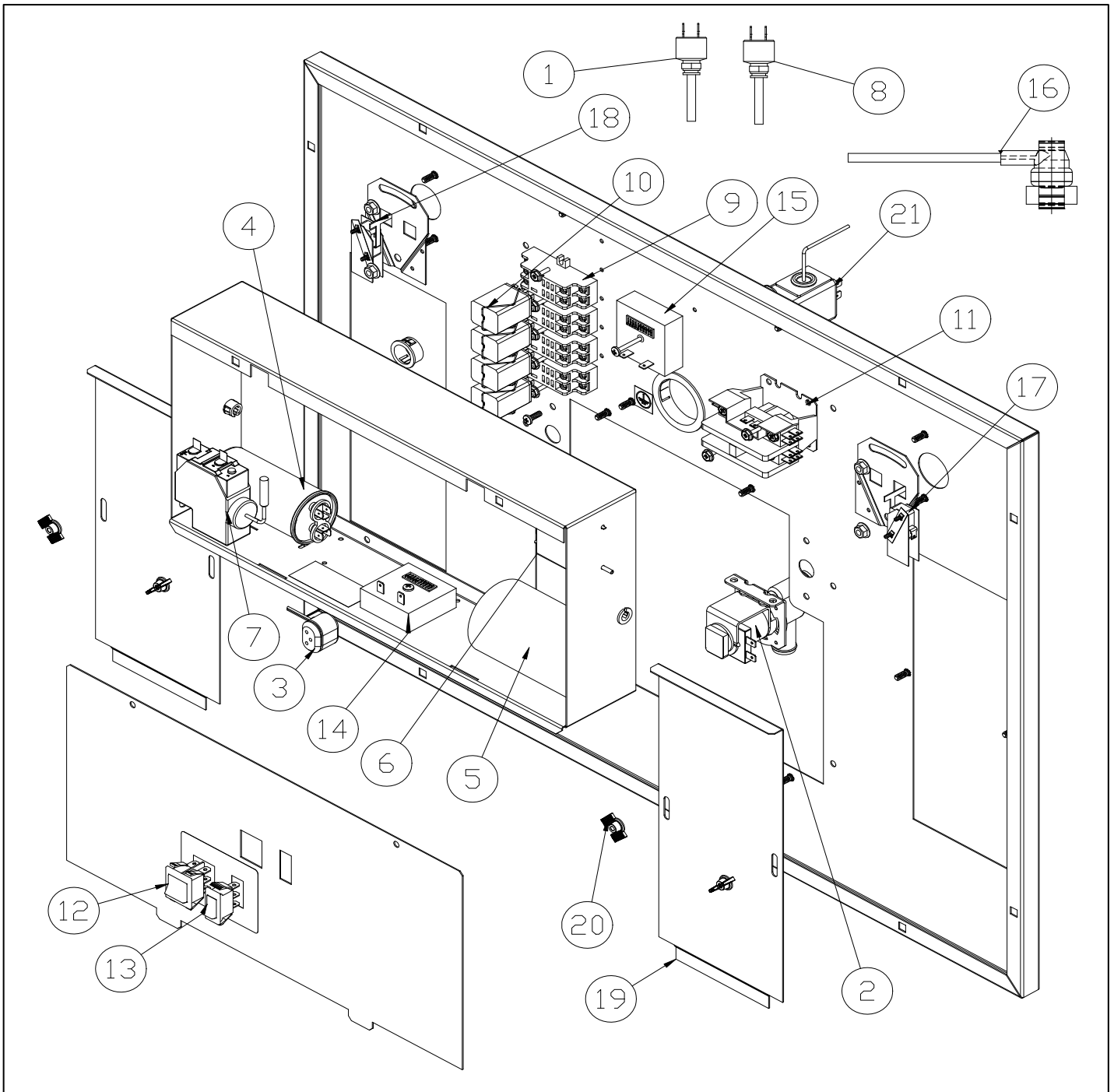

Item No.	Part Number	Description
1	620204475	Pump Down Control
2	620204469	Purge Valve
3	620204798	Water Pump Cord
4	620204674	Run Capacitor
5	620204652	Start Capacitor
6	620204676	Start Relay
7	620204476	Timer Initiate Control
8	620204474	High Pressure Control
9	620204548	Relay Socket
10	620204551	Relay 230 Volt
11	620204545	Contactors

Item No.	Part Number	Description
12	620204557	Selector Switch
13	620204553	Purge Switch
14	620204555	Timer (4 Second)
15	620204555	Timer (Cube Size)
16	620204472	High Temp Safety
17	620204552	Limit Switch
18	620204552	Limit Switch
19	620204363	Access Panel
20	620204459	Nylon Wing Nut
21	620204463	Bin Thermostat

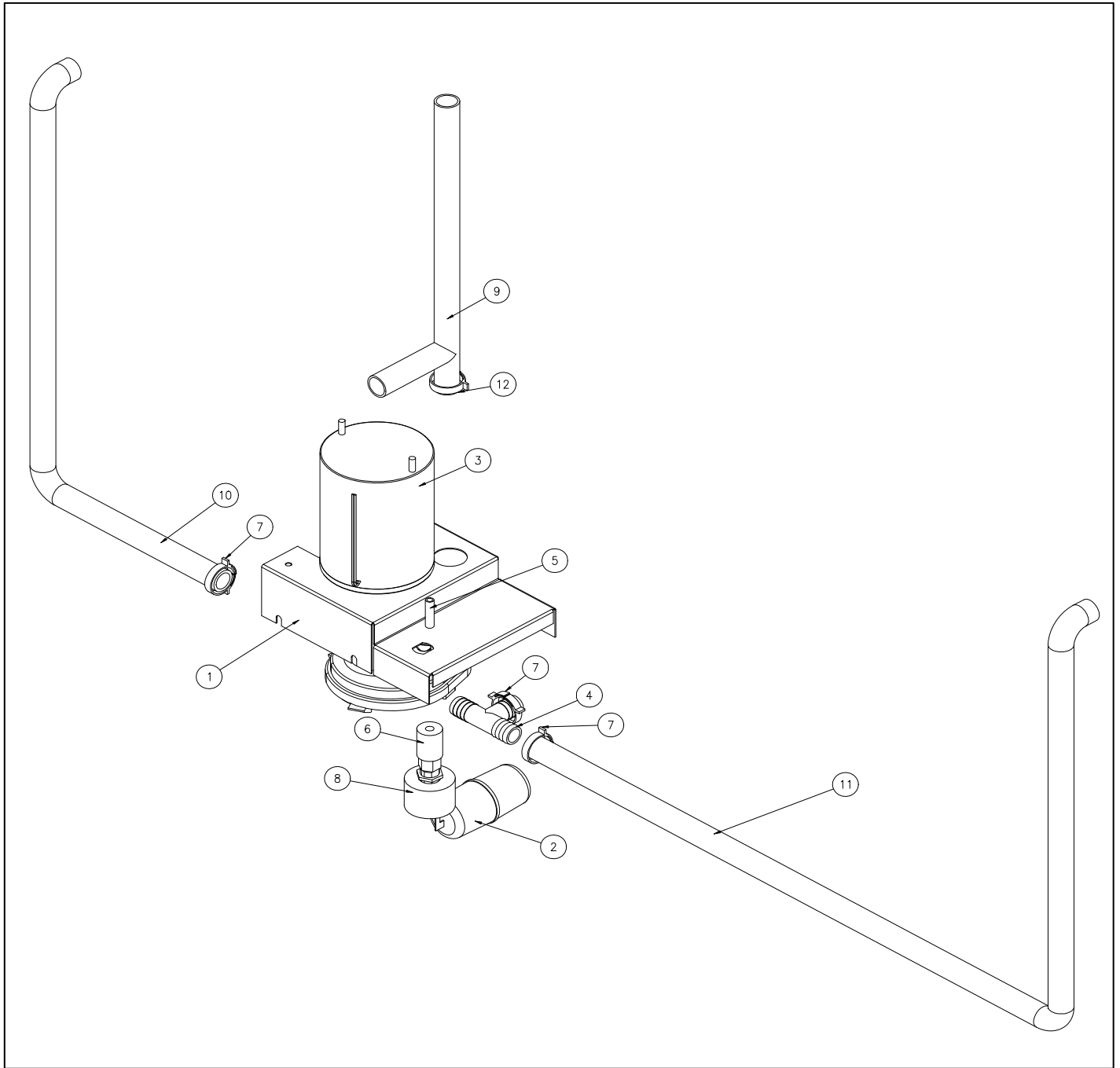

Item No.	Part Number	Description
1	620204352	Water Pump Bracket
2	620204565	Float Assembly
3	620204639	Water Pump
4	620204528	Barbed Tee
5	620204405	ID Plastic Tubing-40 inches long
6	620204410	1/4 " x 40" Long Insulation
7	620204420	Hose Clamp
8	620204563	Cap Plug
9	620204797	Purge/Pump Tube
10	620204513	Water Tube Evap Left
11	620204515	Water Tube Evap Right
12	620204421	Hose Clamp

Distributed By:
Commercial Refrigeration Service, Inc.
WWW.866IceMakers.COM
866-IceMakers
623-869-8881

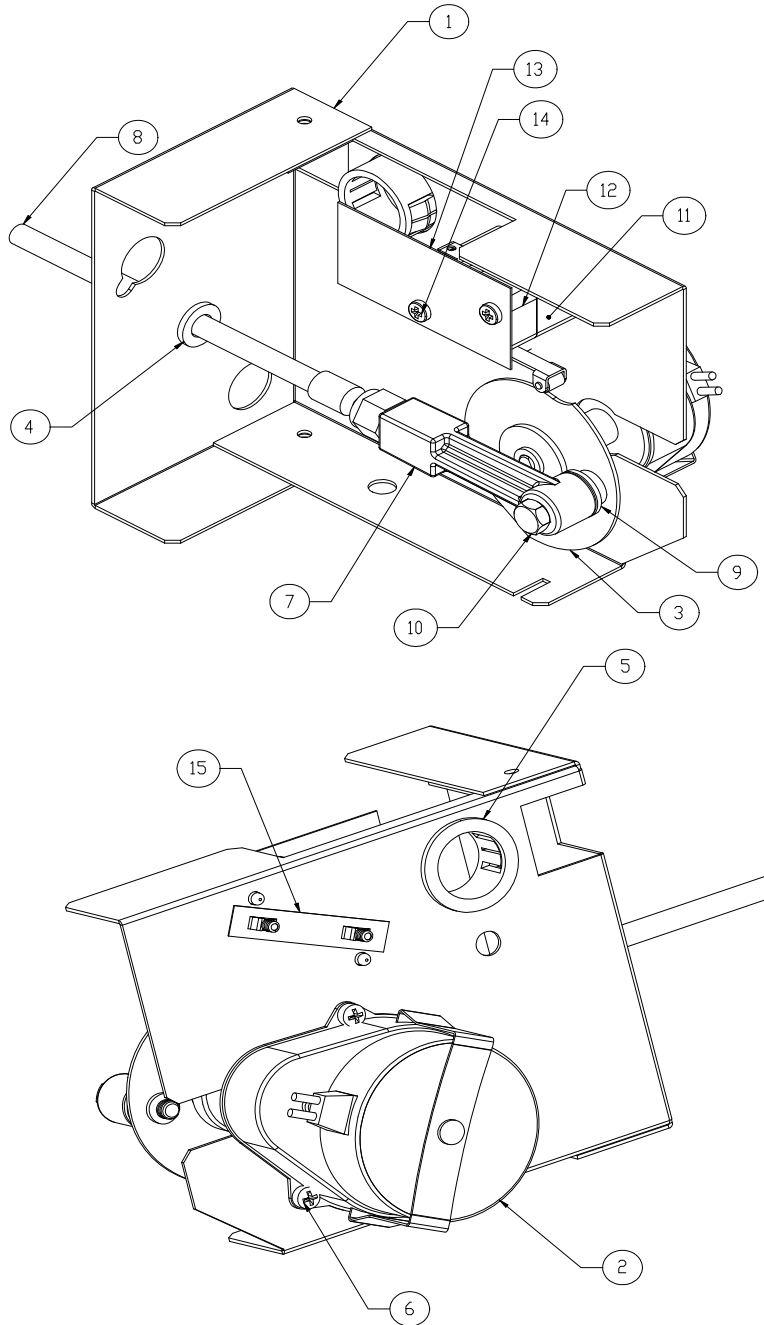

Item No.	Part Number	Description
1	620204366	Bracket, Probe Motor
2	620204631	Gear Motor
3	620204571	Clutch Assembly .312 rad
4	620204483	Snap Bushing
5	620204481	Snap Bushing
6	620204439	#6-32 x 1/2 Screw
7	620204484	Connecting Rod

Item No.	Part Number	Description
8	620204424	Probe, Single Length
9	620204427	Plain Flat Washer
10	620204451	Shoulder Screw
11	620204516	Spacer, Cam Switch
12	620204556	Cam Switch
13	620204407	Insulator, Switch
14	620204434	Pan Head Machine Screw
15	620204452	Speed Nut Plate
	620204313	Complete Assembly

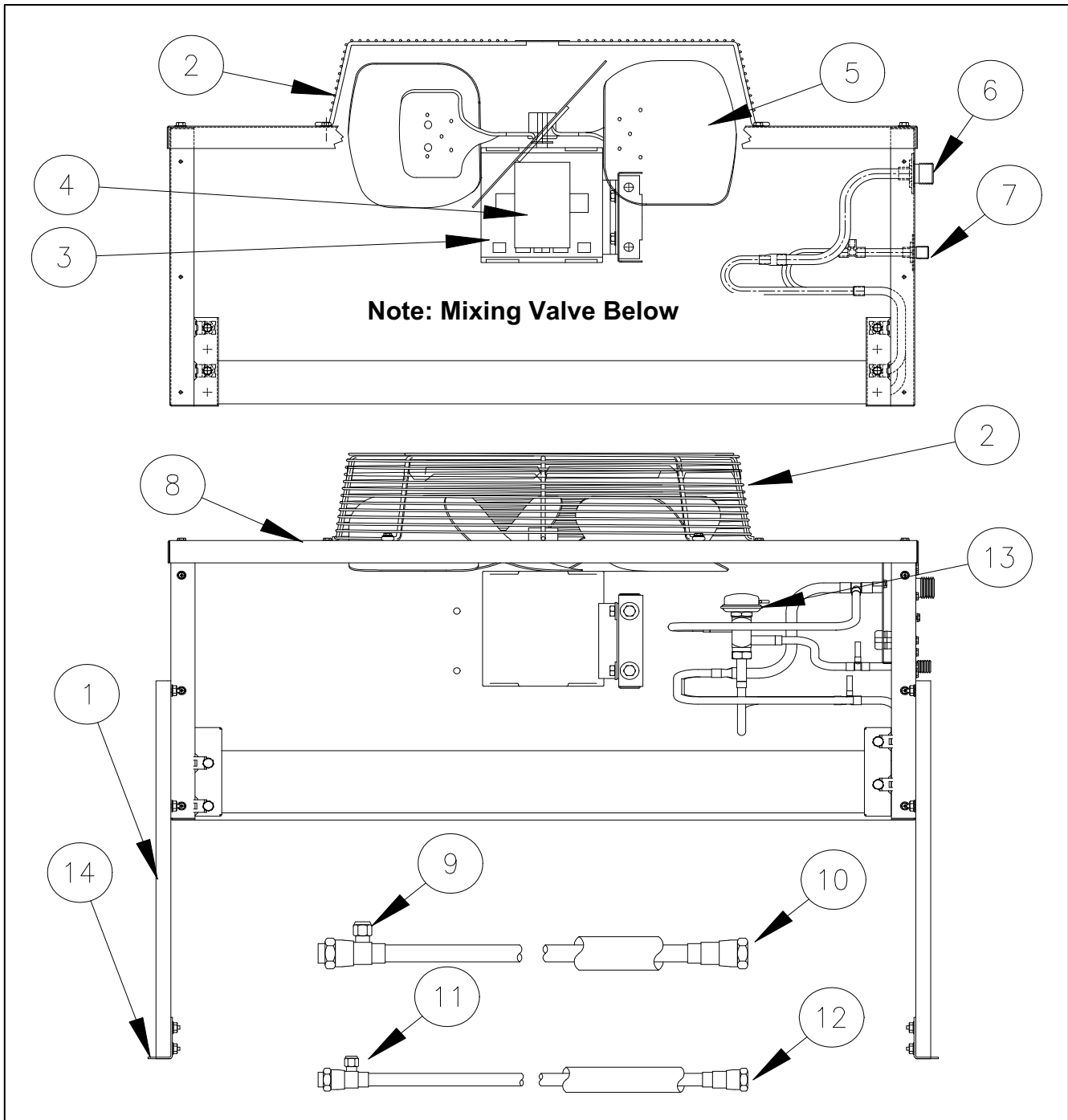

Item No.	Part Number	Description
1	620204361	Mounting Leg
2	620204575	Fan Guard
3	620204642	Fan Motor
4	620204643	Capacitor
5	620204576	Fan Blade
6	620204527	Coupling-Bulkhead-1/2"

Item No.	Part Number	Description
7	620204526	Coupling-Bulkhead-3/8"
8	620204360	Top Panel
9	620204525	Coupling Half 1/2" w/port
10	620204524	Coupling Half 1/2"
11	620204523	Coupling Half 3/8" w/port
12	620204522	Coupling Half 3/8"
13	620204605	Mixing Valve
14	620204796	Leg Brace

Distributed By:
Commercial Refrigeration Service, Inc.
WWW.866IceMakers.COM
866-IceMakers
623-869-8881