

JET SPRAY

OWNER'S MANUAL FOR

Powdered Hot Chocolate Dispenser

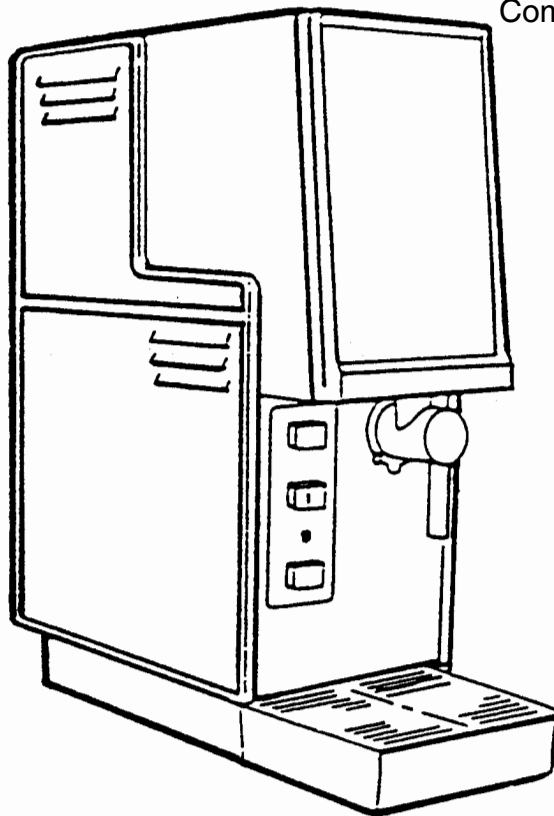

Distributed By:
Commercial Refrigeration Service, Inc.
WWW.IceCubes.NET
WWW.JetsprayParts.COM
(866) 423-6253
(623) 869-8881

<u>MODEL</u>	<u>MODEL No.</u>
HC20	A4400
HC20-W25	A6050
HC20CF	A4444
HC20-W26	A9416

*This manual applies to models of
Serial Number 314936 or higher.*

Manufactured by IMI Cornelius/JetSpray
2401 No. Palmer Drive, Schaumburg, IL 60196
US & Canada ph: 1-888-248-5568 Outside the US ph: 1-630-539-5050
US & Canada Fax: 1-800-344-3801 Outside the US Fax: 1-630-539-6960

April 1999
Printed in U.S.A.

Document No. 14376
Revision No. 18

Your Standard of Excellence for Beverage Merchandising on Six Continents

GENERAL DESCRIPTION

MODEL HC20

The HC20 Powdered Hot Chocolate Dispenser is a compact, lightweight, countertop unit designed to dispense a timed, small or large, portion of hot chocolate by pressing a button. A simple connection to an electrical outlet and a water source is all that is required to set the unit into operation.

MODEL HC20CF

The HC20CF Powdered Hot Chocolate Dispenser is a compact, lightweight, counter-top unit designed to dispense a continuous flow of hot chocolate by the push button.

- WARNINGS:**
1. **THIS APPLIANCE MUST BE EARTHED**
 2. **THIS APPLIANCE IS NOT SUITABLE FOR USE BY UNSUPERVISED CHILDREN**

INSTALLATION

LOCATION

Place the dispenser on a solid level surface with no part of the unit extending beyond the edge of that surface.

POWER AND WATER

- 1) Model **HC20/HC20CF** plug the power cord into a 120 volt 60Hz grounded receptacle.
- 2) Model **HC20-W25** plug the power cord into a 230 volt 50Hz grounded receptacle.
- 3) Model **HC20-W26** plug the power cord into a 220 volt 60Hz grounded receptacle.

NOTE: *As the colors of the wires in the mains lead of this appliance may not correspond with the colored markings identifying the terminals in your plug, proceed as follows (W25 and W26 only):*

- The green and yellow wire must be connected to the terminal in the plug marked with any of the following:
 - ▶ the letter E
 - ▶ the earth symbol
 - ▶ colored green
 - ▶ colored both green and yellow.
- The blue wire must be connected to the terminal in the plug marked with the letter N or colored blue.
- The brown wire must be connected to the terminal in the plug marked with the letter L or colored orange.

- 4) Connect a 1/4" OD flared, flexible, copper water line (10-125 psig water supply) to the unit at the back where the flare fitting is provided. Flush water line by running water through it, to remove any foreign particles before connecting to unit.

NOTE: *It is advisable to have a separate shutoff and strainer installed in the water line.*

- 5) After the connection is made, be sure that the water supply is turned on.
- 6) Turn on the power switch located in the upper left hand corner of the front panel (when facing the dispenser). Red light will glow to indicate unit is on.
- 7) By turning on the power switch, the water tank will automatically fill. *If water does not fill the tank, check to be sure water supply is turned on.*
- 8) When the tank is nearly full, the heater will turn on automatically and the water fill will automatically shut off.
- 9) The water will reach the preset thermostatically controlled temperature in 10-15 minutes. The thermostat is set for 170°F (77°C) and normally needs no adjustment.

-
- 9) **HC20 ONLY** - Set the beverage quantity selector switch to the desired setting - small/6oz. or large/8oz. If the unit is to be used in a self-service cafeteria, the drink size selector switch may be set and secured by ordering cafeteria kit S7736.

POWER CORD

If the supply cord of this appliance is damaged, it must be replaced by a repair shop appointed by the manufacturer because special tools are required.

OPERATION

Precise and simple operation is a design feature of the Jet Spray Powdered Chocolate Dispenser.

CLEAN BEFORE INITIAL FILL

Clean the powder system before initial fill by following instructions on page 4.

START-UP

Remove the hood by lifting up. Open the hopper cover, then fill the hopper with your product. *Do not pack product down.*

DISPENSING

Model HC20

Portion Control - First select the 6oz or 8oz factory set cup size. To dispense a drink, push cup button momentarily, then release. The cup will fill automatically. Adjustment may be made to provide a stronger/ weaker drink or for the use of a larger or smaller cup. Dispense and sample two or three cups of product to determine if the unit is set to dispense desired strength and quantity. If an adjustment is necessary, refer to the operating adjustments section for instructions.

Hot Water Only - For hot water only, push and hold hot water button until cup is almost full, then release.

Model HC20CF

Continuous Flow - Push and hold cup button until cup is almost full, then release. Dispense and sample two or three cups of product to determine if the unit is set to dispense desired strength and quantity. If an adjustment is necessary, refer to the operating adjustments section for instructions.

OPERATING ADJUSTMENTS

WARNING: DANGEROUS VOLTAGES ARE STILL PRESENT WITHIN THE UNIT EVEN IF THE POWER SWITCH IS TURNED OFF. BEFORE ATTEMPTING ANY ADJUSTMENTS INSIDE THE UNIT, TURN THE UNIT OFF AND UNPLUG IT FROM THE ELECTRICAL RECEPTACLE.

The dispenser is factory set to deliver 6oz and 8oz drink sizes, however, it can be adjusted from 5 to 18 ounces by adjusting the portion control timer. Stronger or weaker drinks can be easily obtained by adjusting the ratio control.

1. **RATIO CONTROL - POWDER TO WATER** The ratio is controlled by the water adjustment screw located on the top of the solenoid valve behind the left hand upper panel (see Fig. 1).
 - a) To adjust water flow use allen wrench provided. Loosen lock nut. Put wrench through hole in screw on top of solenoid and rotate counter-clockwise for a weaker drink, or clockwise for a stronger drink. Once desired flow is obtained, tighten lock nut.
 - b) Changing the ratio may necessitate readjusting the portion size to accommodate the new water flow rate. Try a cup and determine if portion size has changed significantly.
2. **PORTION CONTROL ADJUSTMENT** - (Model HC20 Only) Adjustments in drink size are made by simply turning the dials on the Universal Timer (see Fig. 2).

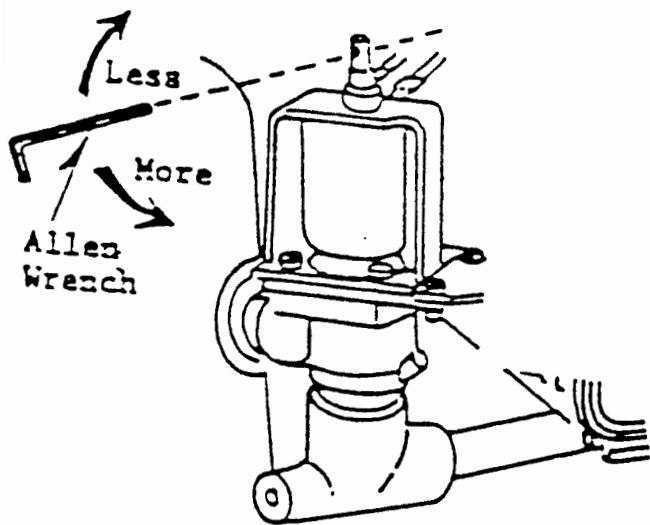

Fig. 1

LARGE DRINK

The same procedure must be followed as above but, for the large drink selection, place the selector switch in the large position and dispense a test drink. Repeat the adjustments to the "large" dial until the desired portion has been reached.

This procedure can also be used for large changes in the portion sizes. Any two sizes, from 3.0 to 18 ounces (86 to 532 cc), may be selected. The HC20 unit is factory set for a 2oz (59cc) differential, 6oz (180cc) small, and 8oz (237cc) large.

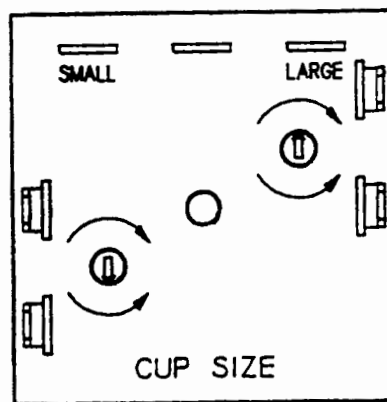

Fig. 2

SMALL DRINK

Turn the "small" dial on the Universal Timer clockwise to increase drink size or counter-clockwise to decrease drink size. After the adjustments have been made, plug in the unit, turn on power, place the selector switch in small position, and dispense a test drink. Repeat this procedure until the desired portion has been reached making sure unit is turned off and unplugged while making adjustments.

TEMPERATURE ADJUSTMENT

The water temperature inside the hot water tank may be adjusted between 133°F(56°C) and 195°F(90.5°C) by changing the thermostat located on the side of the tank. Follow the procedure outlined below when adjusting the temperature.

WARNING: TURN OFF POWER AND UNPLUG FROM ELECTRICAL RECEPTACLE.

1. Remove left hand lower side panel.
2. Using a flat-head screw-driver, turn the adjusting screw on the thermostat: clockwise to increase temperature or counter-clockwise to decrease temperature.
3. Replace side panel, plug in and turn on power.

NOTE: It will take a couple of minutes for the unit to increase the water temperature so wait before testing. Repeat steps 1-3 if further adjustments are necessary.

CLEANING

The Jet Spray hot chocolate mixing system is self-cleaning. Each time a beverage is dispensed, hot water flushes the water system. However, periodic cleaning of the powder system and cleaning of the exterior cabinet and components is necessary for satisfactory operation (see Fig. 3). Proceed as follows:

A. POWDER SYSTEM

1. Remove hood and make sure power switch is in the "OFF" position.
2. Remove hopper assembly.
 - a. Remove parts from assembly as shown in Fig. 3. Do not remove the spring wiper from the auger.
 - b. Wash all hopper parts in warm (not hot) soapy water and rinse thoroughly. Do not put in dishwasher. Dry parts thoroughly before reassembling.
3. Remove the funnel cap and funnel from whipper chamber.
4. Rotate the whipper chamber clockwise and remove it.
5. Remove the impeller blade from the motor shaft.
6. Wash all removed parts in warm soapy water and rinse thoroughly.
7. Do not use steel wool, abrasive or solvent base cleaners on any part of the unit.

B. DISPENSER CABINET

1. The outside of the dispenser should be wiped with a clean, damp cloth and mild soap.
2. **Do not use abrasive or solvent base cleaners!** Soap and water will keep the dispenser sparkling clean and attractive.
3. Empty and wash the drip tray daily.

C. WATER STRAINER

Depending upon water conditions, the inlet water line strainer should be checked periodically and back-flushed to clean out collected residue. If the strainer cannot be back-flushed, replace with a new strainer.

HOPPER ASSEMBLY

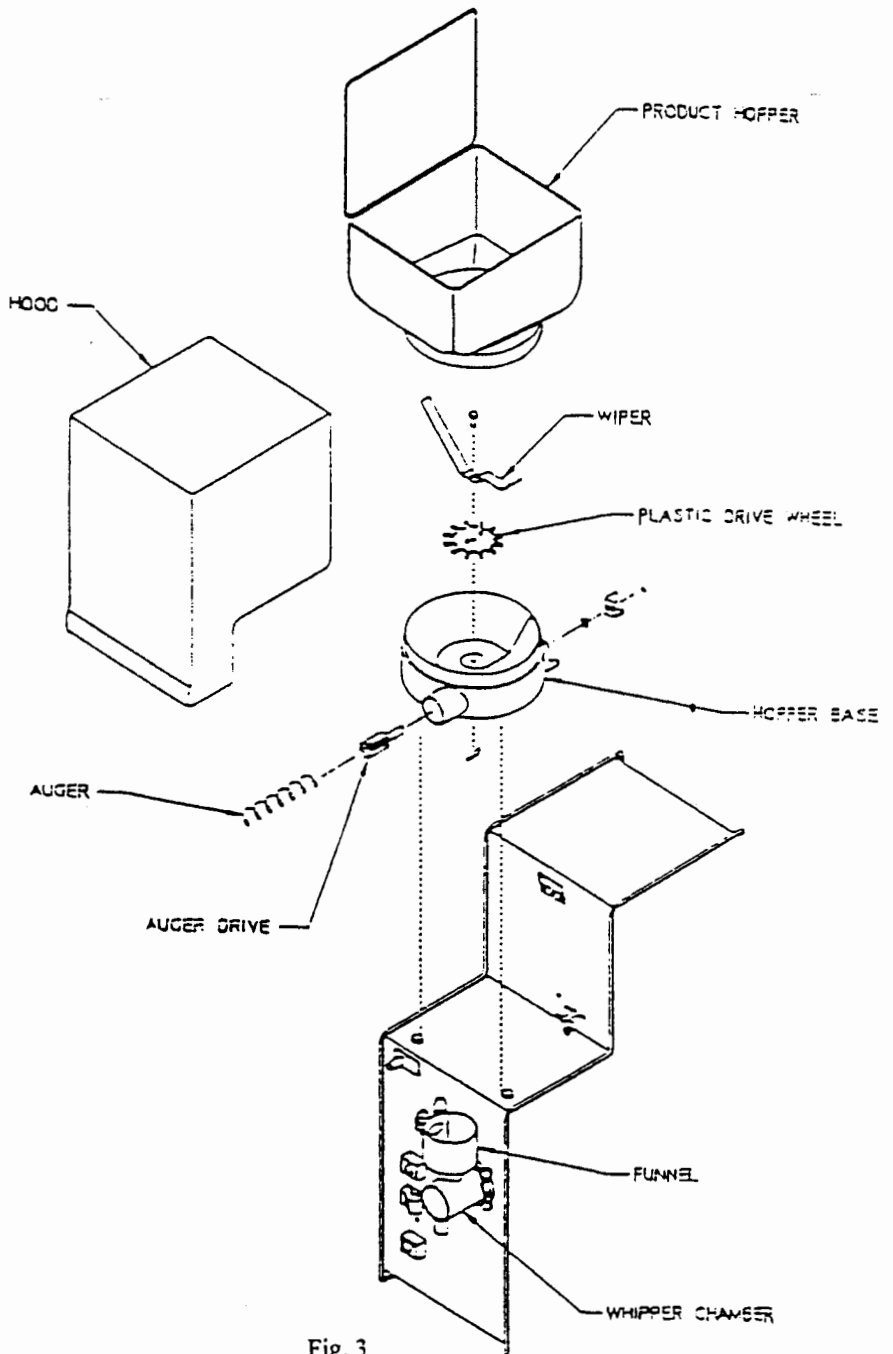

Fig. 3

SERVICE TIPS

- Do not clean plastic parts with hot water, abrasives, or solvents.
- Do not clean dispenser cabinet with any abrasives or solvents.
- In certain area the water supply may be a problem. Certain areas have water with a high mineral content which can result in scale formation inside the heater tank and reduce its life and efficiency. Other areas may have off-odors in the water which results in a poor tasting drink. If you have these problems, consult a local water treatment expert such as Everpure or other reputable companies. These people have equipment which can eliminate the problems just mentioned.

DRAINING OF THE TANK

1. Turn power switch off.
2. Unplug dispenser, remove water reservoir and drip tray. Carry unit to counter next to sink, or have a two gallon water container handy.
3. Loosen drain plug at rear of unit. Do not remove completely.
4. Place unit over sink or other suitable container and remove drain plug. Tank holds 1.5 gallons (5.7 liters) of water.
5. After drainage replace plug and tighten securely.

WARNING: DO NOT STORE UNIT IN SUBFREEZING LOCATION WITHOUT FIRST DRAINING WATER SYSTEM OR DAMAGE TO UNIT WILL RESULT.

SPECIFICATIONS

Portion Control Models	Specifications
HC20	120 VAC 60Hz 1720 W 14 Amps
HC20-W25	230 VAC 50Hz 1868 W
HC20-W26	220 VAC 60Hz 1711 W
Inlet Water Pressure	<u>psi</u> <u>Kpa</u> <u>Bar</u>
Min (Static)	10 68.9 0.69
Max (Static)	125 861.3 8.6
Min (Dynamic)	20 137.8 13.8
Continuous Flow Models	
HC20CF	120 VAC 60 Hz 1720W 14Amps
Size:	8- ¹ / ₁₆ "W x 18- ⁵ / ₈ "D x 21"H (20.4 x 47.3 x 53.3 cm)
Cabinet:	Stainless Steel Exterior Impact Resistant Hood & Drip Tray
Controls:	
HC20	Small Cup, Large Cup, Hot Water
HC20CF	Continuous Flow
Portion Size:	Factory set for Small-6oz, Large-8oz
(portion control units only)	
Maximum Drink Size:	18oz (532cc)
Stainless Steel Water Tank:	1.5 Gallons (5.7 liters)
Dispensing Rate:	
HC20/HC20CF	120 6oz (177ml) Cups/hr
HC20-W25	160 6oz (177ml) Cups/hr
HC20-W26	160 6oz (177ml) Cups/hr
Heater:	
HC20/HC20CF	1500 W @ 120 VAC Incoloy Removable
HC20-W25	2000W @ 240 VAC Incoloy Removable
HC20-W26	2000 W @ 240 VAC Incoloy Removable
Drip Tray:	Removeable - Impact Resistant
Net Weight:	30lbs (13.5kg)
Shipping Weight:	32lbs (14.5kg)

NOTES

Attention is drawn to the requirements of National Regulations about connecting to and using Potable water supplies. Jet Spray dispensers conform to the requirements of the Model Water Bylaws of 1986 SI 1147.

All hoses and couplings are capable of withstanding 1.5 times the rated operating pressure for 30 minutes at 50°C after being aged for 10 days at 70°C.

All surfaces which come into contact with food or drinking water are constructed of food quality non-toxic materials, are non-corrosive, non-tainting and do not support the growth of bacteria.

Jet Spray Corporation reserves the right to make changes in design and/or engineering without notice.

HC20 WIRING DIAGRAM

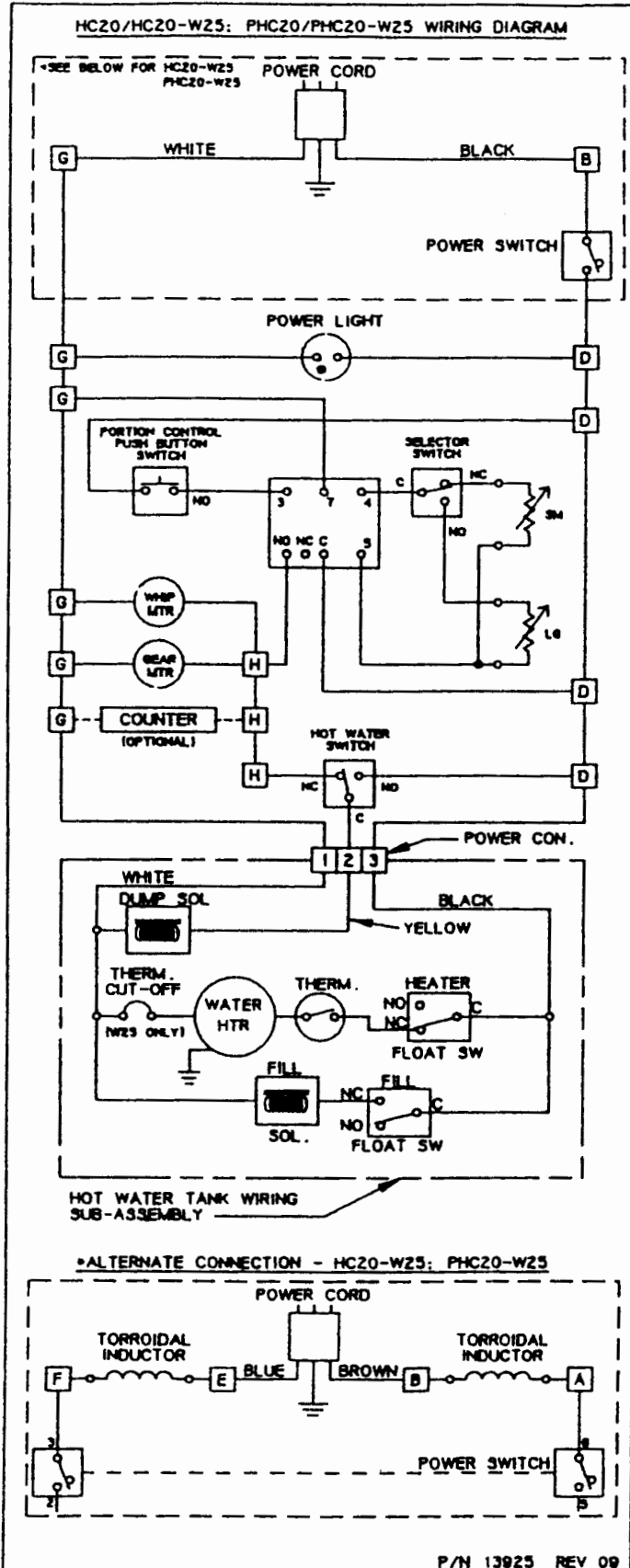

HC20CF WIRING DIAGRAM

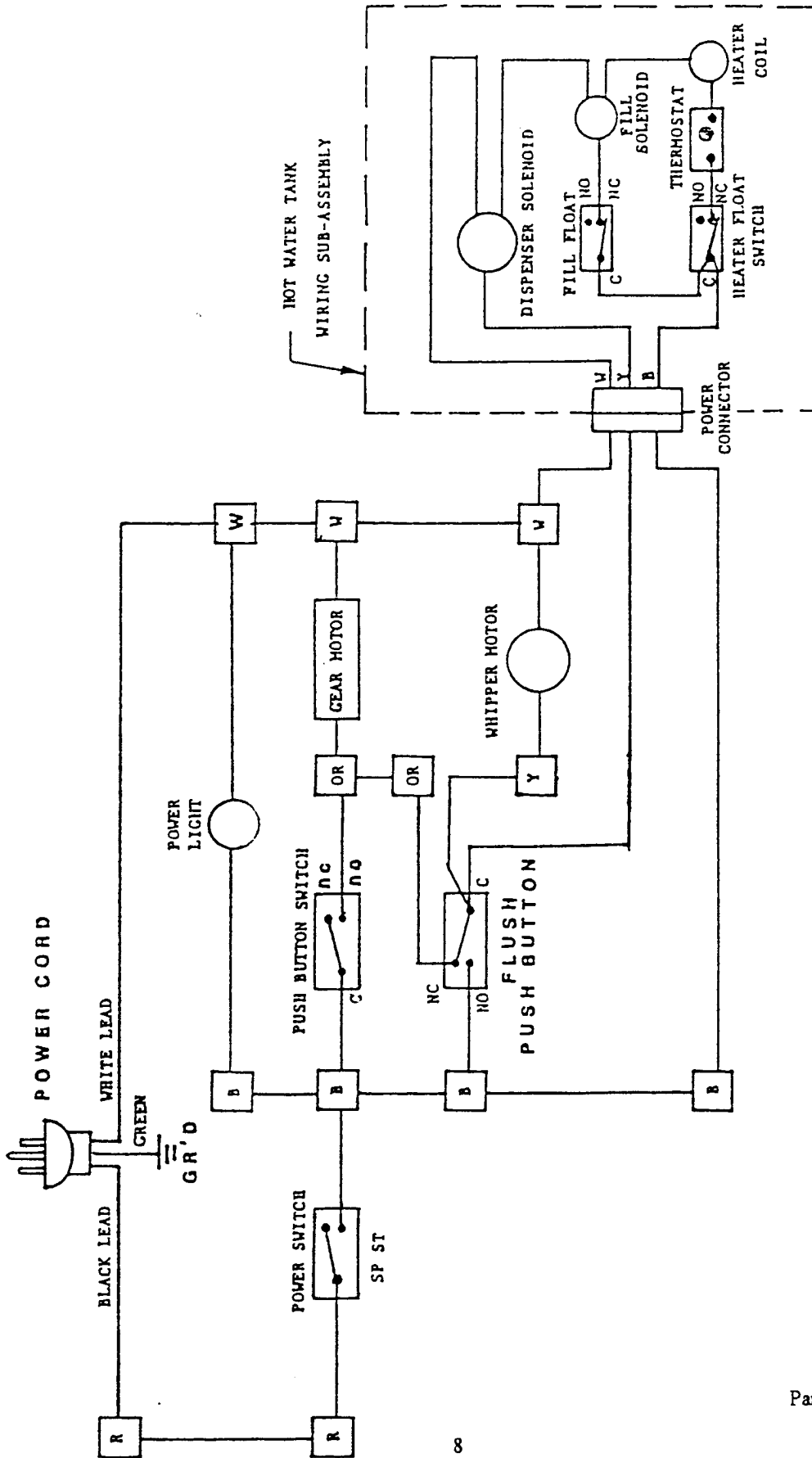

Part No: 14595
Rev. 04

HC20CF WIRING DIAGRAM

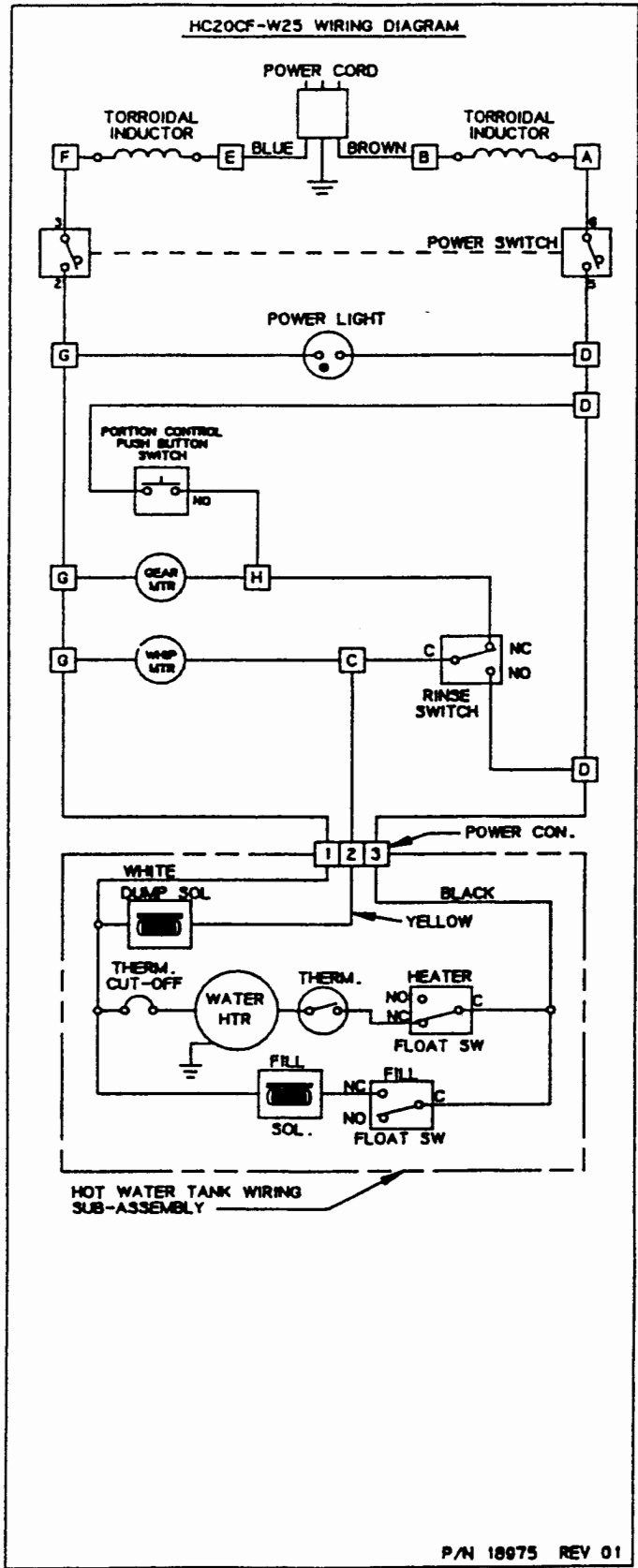

HC20/HC20-W25: PHC20/PHC20-W25 WIRING DIAGRAM

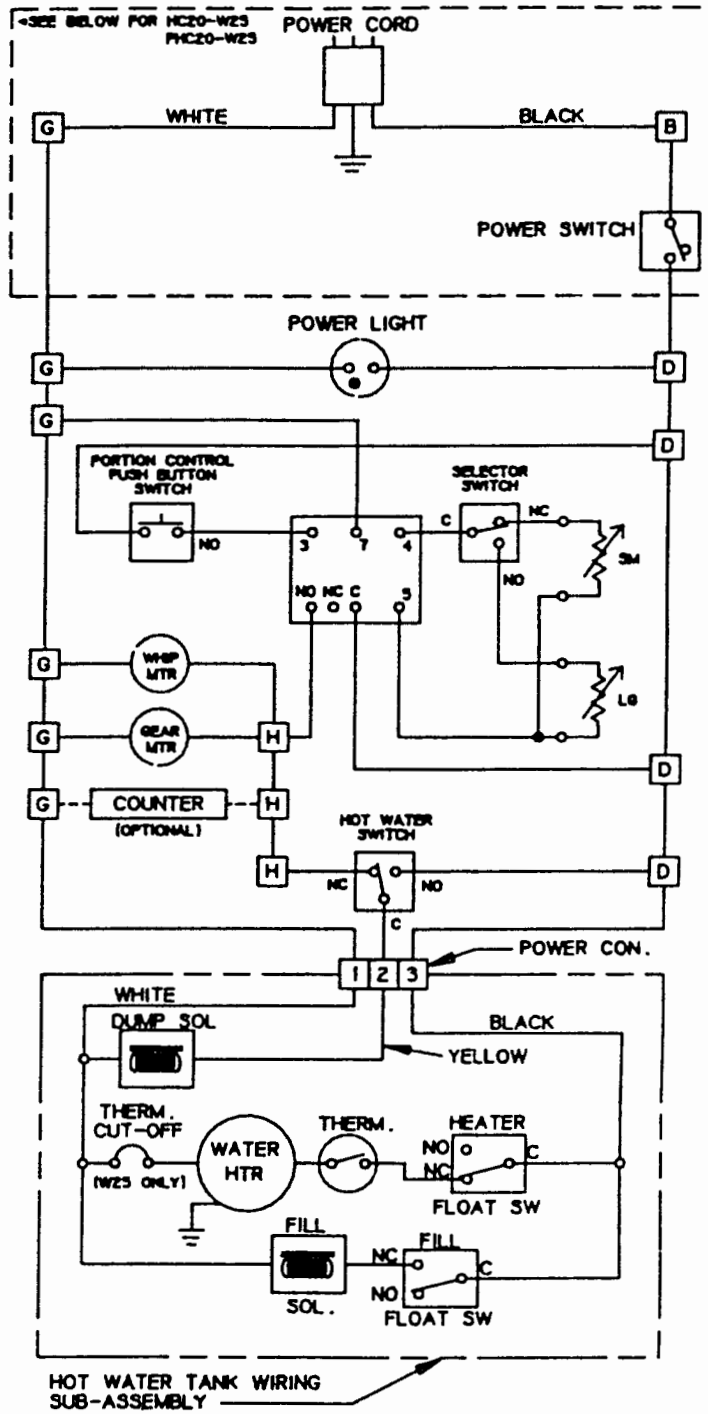

•ALTERNATE CONNECTION - HC20-W25: PHC20-W25

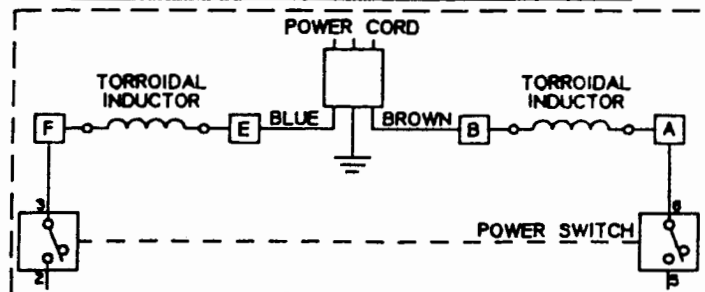

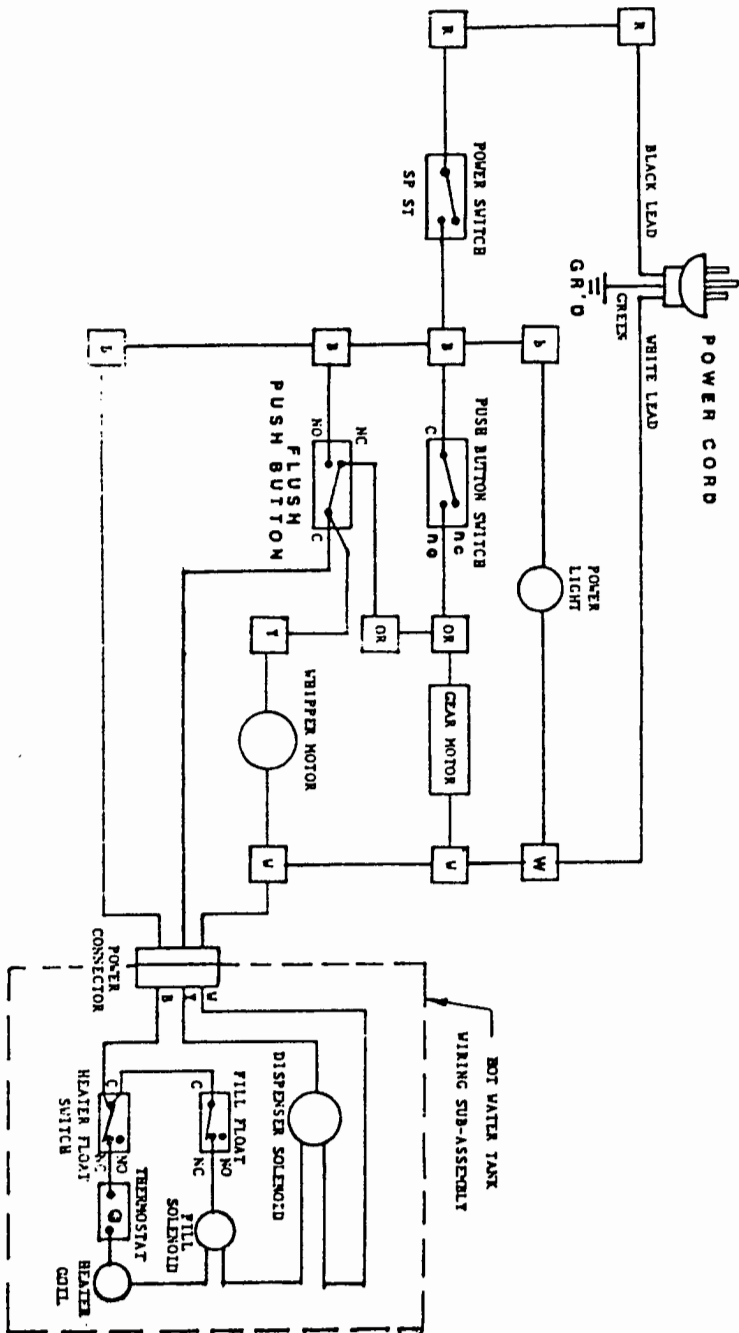

HC20CF WIRING DIAGRAM

PART No:14595
 R E V . 01

