

JET-SPRAY

OWNER'S MANUAL FOR VISUAL DISPLAY DISPENSER

JT20

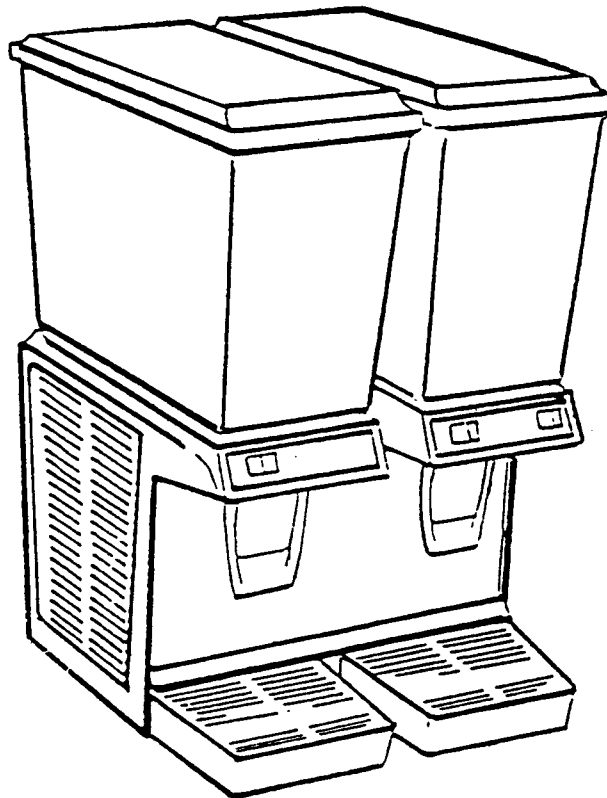

MODEL

**JT20
JT20-W25
JT20-W26
JT20 - JAPAN**

Refrigerant R134a

***This manual applies to models of
Serial Number 305029 or higher.***

**Manufactured by IMI Cornelius/JetSpray
2401 N. Palmer Drive, Schaumburg, IL 60196
US & Canada ph: 1-888-248-5568 Outside the US ph: 1-630-539-5050
US & Canada Fax: 1-800-344-3801 Outside the US Fax: 1-630-539-6960**

**June 1996
Printed in the U.S.A.**

**Document No. 18479
Revision No. 05**

General Description

The JT20 dispenser is a countertop visual display action beverage dispenser.
It is designed to dispense a variety of products.

- Warning:**
1. This appliance must be earthed.
 2. This appliance is not suitable for use by unsupervised children.

Location

Place the dispenser on a solid, level surface with not part of the unit extending beyond the edge of that surface.

Power and Water

The JT20 requires a 120 Volt, 60Hz grounded receptacle for the unit's power cord.

The JT20-W25 requires a 230V, 50Hz earthed receptacle for the unit's power cord.

The JT20-W26 requires a 208V/230V, 60Hz earthed receptacle for the unit's power cord plug.

Note: *If the colors of the wires in the main leads of this appliance do not correspond with the colored markings identifying the terminals in your plug, proceed as follows.*

-The green and yellow wire must be connected to the terminal in the plug marked with any of the following:

- the letter E •colored green
- the earth symbol •colored both green and yellow

- The blue wire must be connected to the terminal in the plug marked with the letter N or colored blue.
- The brown wire must be connected to the terminal in the plug marked with the letter L or colored orange.

Power Cord

If a power cord is damaged, do not attempt to replace it. Take your unit to your nearest authorized service center as a special tool is required.

Operating Adjustments

Warning: Dangerous voltages are still present within the unit even if the power switch is turned off. Before attempting any adjustments inside the unit, turn the unit off and unplug it from the electrical receptacle.

Notes:

- ★Attention is drawn to the requirements of National Regulations about connecting to and using Potable water supplies.
- ★Jet Spray dispensers conform to the requirements of the Model Water Bylaws of 1986 SI 1147.
- ★All surfaces which come into contact with food or drinking water are constructed of food quality non-toxic materials, are non-corrosive, non-tainting and do not support the growth of bacteria.

Jet Spray Corporation reserves the right to make changes in design and/or engineering without notice.

Specifications
JT20 Series

A. Electrical

Model	P/N	Electrical Supply	RLA	Running Power	LRA
JT20	A8420	120VAC, 60Hz	5.6 AMPS	672 Watts	24 AMPS
JT20-W25	A8430	230VAC, 50Hz	2.3 AMPS	530 Watts	11 AMPS
JT20-W26	A8450	220VAC, 60Hz	3.3 AMPS	726 Watts	14 AMPS

RLA - Running Load Amperage

LRA - Locked Rotor Amperage (*compressor starting amperage*)

B. Class of Windings

Compressor Motor - Class H (*climatic rating; normal*)

Condenser Fan Motor - Class B

C. Environment

Temperature

Operating: 60°F (16°C) to 110°F (43°C)

Storage: Above - 20°F (-7°C) with bowl empty and dry.

Humidity - Below 95%

D. Refrigeration (R134a refrigerant)

<u>Model</u>	<u>Charge Quantity</u>
JT20	144 grams
JT20-W25	128 grams
JT20-W26	144 grams

INSTALLATION AND OPERATING INSTRUCTIONS

Setting Up Your JT20

1. Set dispenser chassis in desired location. Dispenser should be level and located on a solid counter.
2. Be sure dispenser has adequate free space on both sides; approximately 3" away from any wall or obstruction.

Cleaning the Dispenser

1. Removing the Push Handles (see Fig. 1).

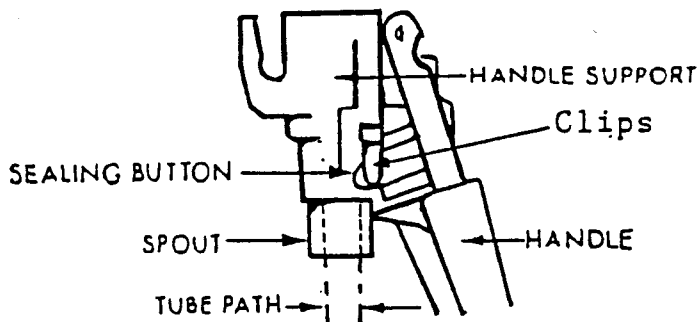

Fig. 1

- a. Push handle back until it stops.
 - b. Grasp clips on handle. Squeeze clips until they are free from panel. Pull straight down on handle.
2. Disassemble the bowl, lid, gasket, and pump housing assemblies.

Note: To remove pump housing, push back on top of housing just below spray tube and lift up and out of bowl. Clean in warm water and mild nonabrasive detergent and rinse thoroughly.

WARNING: Abrasive cleaners will scratch plastic parts.

To Assemble

1. Slide the drip tray with grille into place.
2. Consider installation of a drain hose which connects to outlet on drip tray bottom (Part No. S-3379).
3. Turn bowl upside down and insert gasket into groove. Wet gasket for ease of insertion, pressing gasket into groove while following numbers (see Fig. 2).

Press while following numbers until gasket is completely seated BOWL SPOUT GASKET

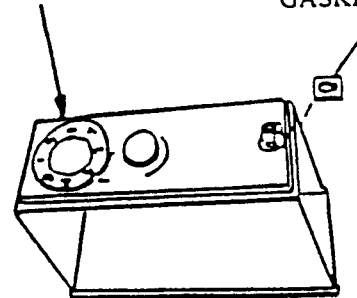

Fig. 2

4. Install bowl spout gasket.
5. Lock pump housing in bowl by pushing housing straight into bowl location until it snaps into position. Press down on top of the impella section to assure it is down all the way into well section (see Fig. 3).

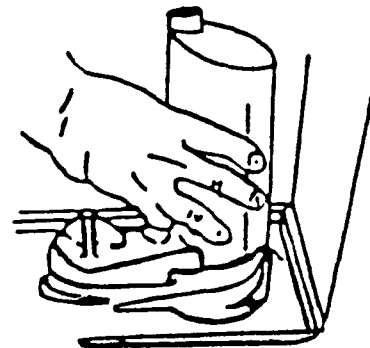

Fig. 3

Note: If a bowl circulator kit is used in place of the pump housing assembly, see Page 5A for assembly.

6. Lock spray tube in by pushing down in opening, then rotate clockwise. Correctly installed, tube will face front of bowl (see Fig. 4 below).

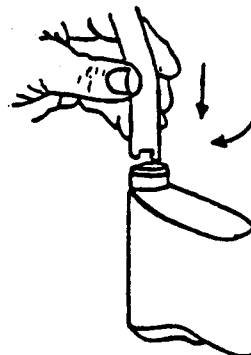

Fig. 4

7. Slide bowl over the cooling tubes and assemble to bowl to the dispenser. Be careful not to wrinkle gasket as it will result in beverage leaking out of bowl (see Fig. 5).

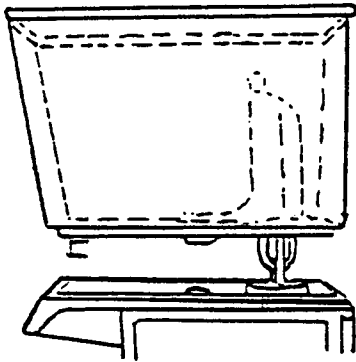

Fig. 5

8. Push down on pump housing to make sure it is in position.
9. Replacing push handle and pinch tube.
 - a. Push handle assembly straight up through rectangular hole until clips snap into place (see Fig. 6).

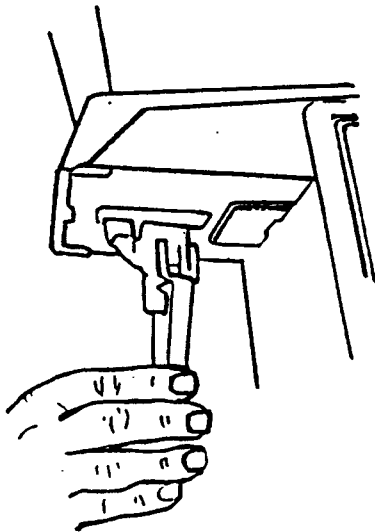

Fig. 6

- b. Remove pinch tube from plastic bag and wash.
- c. Before installing, wet bowl spout surface and pinch tube. Push back handle until it stops.

- d. Carefully insert pinch tube into bowl spout opening and on into lower opening of handle support spout. Make sure end of tube does not get caught on edge above handle support spout opening, pull end of tube for final seating into bowl spout seat. make sure tube is free of wrinkles and extends below support spout above $\frac{1}{4}$ inch (see Fig. 7).

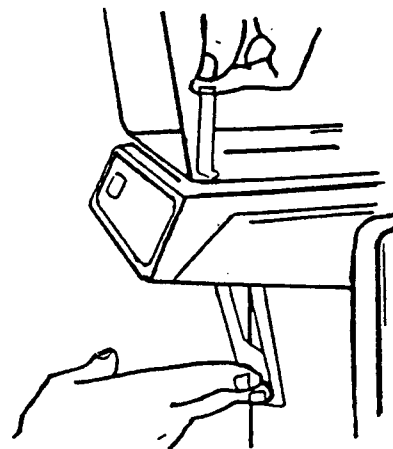

Fig. 7

Operating Procedures

1. Follow beverage manufacturer's directions in filling bowls. To aid in filling, the bowls have gallon and liter markers up the center of the front wall -- gallons on left, liters on right.
2. Turn on the refrigeration and spray switches. Product should be cold enough to serve in 2 hours. Switches should be left "ON" 24 hours a day to insure efficient operation.

Note: If unit is to be used to dispense beverage from only one bowl, use right hand bowl, but add a gallon of water to left bowl to assure proper cooling.

3. The thermostat is preset at the factory and will not normally require resetting by owner.

FREQUENT MAINTENANCE PROCEDURES

Cleaning the Bowls

1. Before removing the bowls, turn off both the refrigeration and spray switch. Unplug unit from power source.
2. Drain beverage from bowls.
3. Remove pinch tube by pushing handle until it stops. Pull up on pinch tube until it is free, then remove handle (see Page 3). Lift off bowls, drip trays, and covers and clean.
4. Clean as described in Paragraph B "Cleaning the Dispenser."
5. After cleaning, assemble as described in Paragraph C. Replace push handle, and insert pinch tube into bowls.

Cleaning Condensate Drains

1. To remove condensation drains, push in on front panel just under drain and pull down with fingers (see Fig. 8).

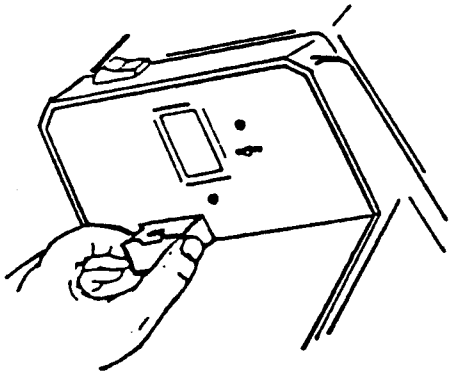

Fig. 8

2. To replace condensate drains, hold drain against front panel under rectangular hole (opening in side of drain should be toward front panel). Push up through hole until drain snaps into place (see Fig. 9).

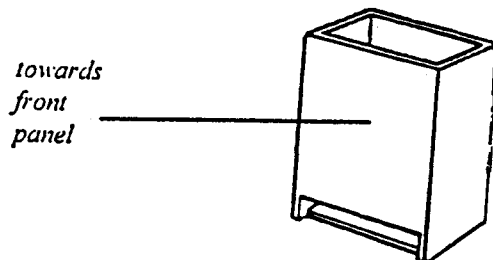

Fig. 9

Sanitizing Unit

After cleaning, add one gallon of water between 75°F and 100°F to bowl. Mix one tablespoon of approved powdered chlorine sanitizer* in a pint of water and when dissolved, pour into bowl. Replace lid and run unit two or three minutes. Then shut off unit and drain contents through valve.

*Diversey-MultiChlor or equivalent powder or liquid sanitizer.

Warning: Do not run refrigeration switch when sanitizing.

Ventilation

AIR FLOW IS ESSENTIAL. ALLOW AT LEAST 3 INCHES OF SPACE ON BACK AND SIDE OF DISPENSER. LINT OR DUST COLLECTING ON THE CONDENSER WILL RESULT IN POOR REFRIGERATION.

Cleaning Condenser

1. Turn off Refrigeration Switch.
2. Remove right side panel. Clean filter(s) by running a stream of hot water through the inside surface of filter(s), and allow to dry. Filter(s) should be replaced, if necessary. (See Parts List).
3. Clean condenser with vacuum cleaner or brush making sure no loose dirt goes into the dispenser.
4. Clean and replace panels.

Correcting Dispenser Difficulties

No Spray or Circulation

1. Be sure switch is "ON."
 2. If unit does not spray, remove pump housing and check impella. Impella must spin freely. Sugar and solids can crystallize, causing impella to bind. Frequent washing will eliminate this.
- Pump Housing

For New Units: Remove pin holding impella in pump housing by pushing down on top and pulling out on impella magnet. Separate parts and clean (see Fig. 10).

Long pieces of pulp may partially plug pump housing and bind impella blades. Juices with excessive pulp must be strained in order to spray. However, if it is desired to retain pulp, use Jet Spray Circulator Kit No. A1620 in place of the pump housing assembly. Wash sediment from pump well.

5. Pump housing assembly should be locked into place properly (see Paragraph C, Item 5).

Bowl Leaks

1. Do not confuse drippings from condensation on the outside of the bowl as bowl or faucet leaks. High humidity causes more condensation.
2. Be sure gasket has been put on properly. Check gasket for tears or cuts in rubber as they cause leaks.
3. Remove and examine pinch tube for holes.

Fig. 10

3. Circulator - Slide impella up on shaft and clean underside of impella at center. If impella rubs on base of circulator, replace.

Note: Switch must be "OFF" when inserting the pump housing assembly into the bowl to assure magnetic coupling.

JT20 WIRING DIAGRAM

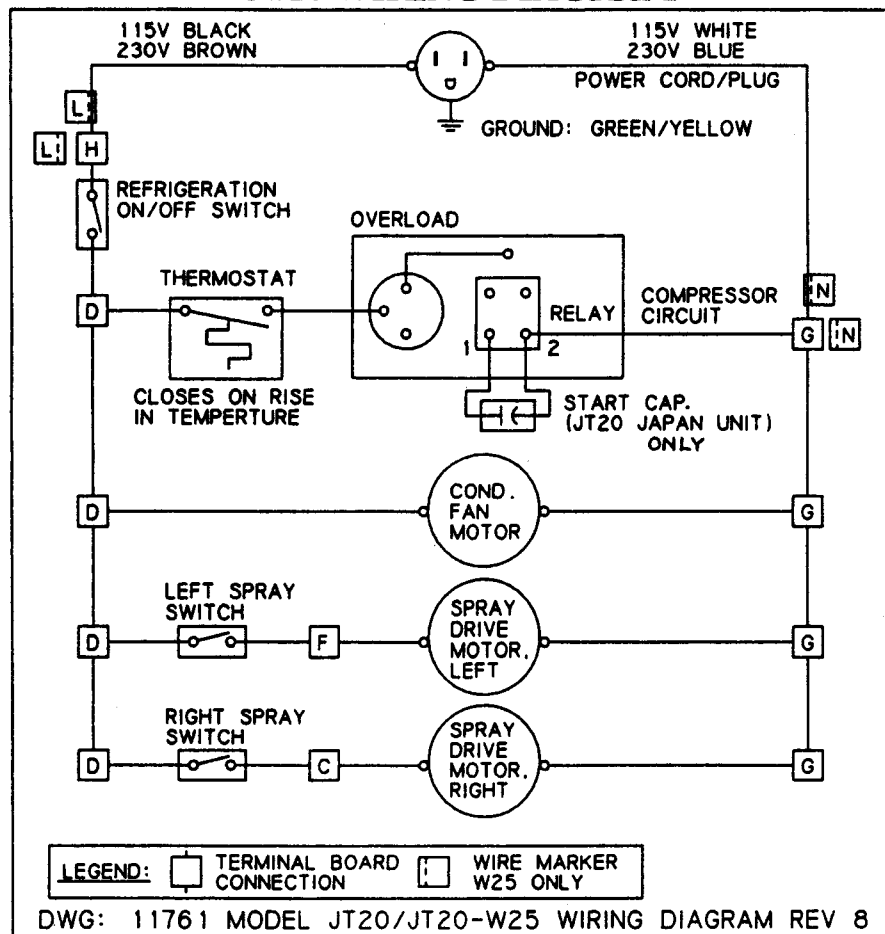

JT20 SPECIFICATIONS

Power Cord:	7' with ground connection (2.1 meters)
Size:	16" wide X 19" long X 26 ⁵ / ₈ " high (19.7 cm wide X 48.3 cm long X 67.7 cm high)
Beverage Bowl & Cover:	Transparent, virtually unbreakable LEXAN® resin.
Cabinet:	Stainless steel and beige LEXAN® resin.
Capacity:	Over 10 U.S. gallons; 40 liters. Over 6 U.S. gallons; 24 liters.
Refrigeration:	Jet Spray ¹ / ₅ h.p. hermetically sealed system.
Refrigerant:	Freon 134a non-toxic, odorless.
Spray Drive and Fan Motor:	No oiling required.
Power Drive Magnet:	Permanent INDOX magnet.
Net Weight:	Base only 51 lbs (193 kgs) Large Bowl 7 lbs (3.2 kgs) Small Bowl 5 lbs (2.3 kgs)
Shipping Weight:	Base only 61 lbs (27.3 kgs) Large Bowl 10 lbs (4.7 kgs) Small Bowl 8 lbs (3.6 kgs)
Carton Cube:	Base only 4.8 cu. ft. (.14 cu. m.) Large Bowl 1.7 cu. ft. (.05 cu. m.) Small Bowl 1.4 cu. ft. (.04 cu. m.)

*We reserve the right to make changes in design and/or engineering without notice.
Should the unit require service, take to nearest Jet Spray authorized service center where
parts and service may be obtained (U.S.A. only).*

*UL listing applies for U.S.A.
**C-UL listing applies for Canadian models only.



Your Standard of Excellence for Beverage Merchandising on Six Continents

JET SPRAY